

Initial Start-Up

To obtain warranty coverage, please fill out and return the warranty registration card now.

Inspection

Inspect the UPS upon receipt. Notify the carrier and dealer if there is damage. The packaging is recyclable; save it for reuse or dispose of it properly.

Placement

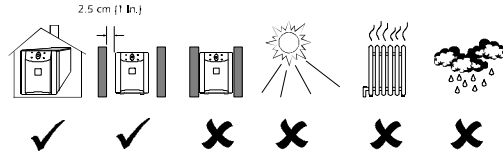

Install the UPS in a protected area that is free of excessive dust and has adequate air flow. Do not operate the UPS where the temperature and humidity is outside the specified limits.

Warning: Changes or modifications to this unit not expressly approved by the party responsible for compliance could void the warranty.

Connect to Utility

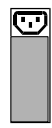
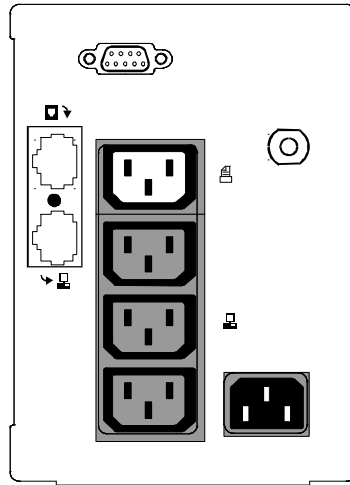
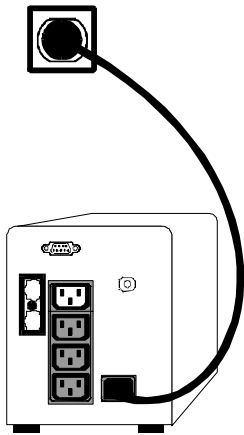

Full Time Surge Protected Outlet

The top-most off-white outlet provides surge protection only. It is rated for 500VA (300W).

Equipment plugged into this outlet should require surge protection, but should not require power during a utility power failure. This could include a laser printer, scanner, fax, or audio device.

Warning: The top outlet has voltage as long as the UPS is connected to an active AC power source. It has voltage even when the UPS is turned off.



Battery Power Supplied Outlets

The lower three outlets provide protection from surges and battery backup protection.

Plug a computer, monitor, and other "data-critical" devices into these outlets. **Never plug a laser printer into the Battery Power Supplied outlets.**

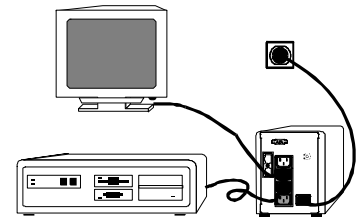

Connect the Loads

Plug the loads into the output connectors on the rear of the UPS. To use the UPS as a master on/off switch, make sure that all of the loads are switched on.

Connect Network Surge Suppression (Optional)

Connect a single 10Base-T/ 100Base-Tx network cable into the RJ-45 network surge protection IN jack on the back of the UPS.

Connect from the OUT jack with network cabling (not supplied) to a network port on the computer.

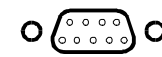

Connect Computer Interface Port (Optional)

PowerChute® plus power management software is included with this UPS. Connect the supplied interface cable to the 9-pin computer interface port on the back panel of the UPS. Connect the other end to a dedicated serial port on your computer. See software documentation for installation instructions.

Charge the battery

The UPS charges its battery whenever it is connected to utility power. The battery will charge fully during the first 4 hours of normal operation. Do not expect full runtime during this initial charge period.

Operating Instructions

Switch On — Switch Off

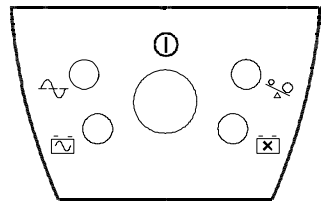

With the UPS plugged in, press and release the on/off/test button to supply power to the loads plugged into the Battery Power Supplied outlets. The equipment plugged into the Full Time Surge Protected outlet (the top outlet) has power whenever the UPS is connected to an active AC power source.

The Battery Power Supplied loads are immediately powered while the UPS performs a self-test. Press and release the button again to turn off power to the loads. It may be convenient to use the UPS as a master on/off switch for the protected equipment.

The on-line LED illuminates when the UPS is supplying utility power to the loads.

Self-test

The UPS performs a self-test automatically when turned on, and every two weeks thereafter (by default). Automatic self-test eases maintenance requirements by eliminating the need for periodic manual self-tests.

During the self-test, the UPS briefly operates the loads on-battery. If the UPS passes the self-test, it returns to on-line operation.

If the UPS fails the self-test it immediately returns to on-line operation and lights the replace battery LED.

The loads are not affected by a failed test. Recharge the battery overnight and perform the self-test again. If the replace battery LED is still on, replace the battery using the Replacing the Battery procedure.

On Battery

During on-battery operation, the on-battery LED illuminates and the UPS sounds an audible alarm consisting of 4 beeps every 30 seconds. The alarm stops when the UPS returns to on-line operation. The alarm may also be disabled using PowerChute® plus power management software.

Low Battery

When the UPS is operating on-battery and the energy reserve of the battery runs low, the UPS beeps continuously until the UPS shuts down from battery exhaustion or returns to on-line operation.

Overload

When loads exceed the UPS's capacity, the overload LED illuminates and the UPS emits a sustained tone. The alarm remains on until the overload is removed. Disconnect nonessential load equipment from the UPS to eliminate the overload.

If the overload is severe, the input circuit breaker may trip (the resettable center plunger of the circuit breaker pops out). Disconnect nonessential load equipment from the UPS to eliminate the overload and press the plunger back in.

If there is AC power and the circuit breaker does not trip during overload, the loads are still powered. If the circuit breaker trips or the UPS attempts to transfer to battery, the loads' power will be shut off. Turn the UPS off then back on to power the loads.



Replace Battery

If the battery fails a self-test, the UPS emits short beeps for one minute and the replace battery LED illuminates.

The UPS repeats the alarm every five hours. Perform the self-test procedure to confirm replace battery conditions. The alarm stops when the battery passes the self-test.

Shutdown Mode

If there is no power, the host connected to the computer interface port can command the UPS to shut down. This is normally done to preserve battery capacity after a controlled shutdown of the protected system. In shutdown mode the UPS stops supplying power to the load. The online and overload LED indicators flash alternately or, if the UPS has shutdown due to a low battery, the UPS will beep once every 4 seconds for approximately 16 seconds. When line power is restored, the UPS will return to on-line operation.

Cold Start

Note: Cold start is not a normal operating condition.

When the UPS is off and there is no utility power, it is possible to cold start the UPS to power the loads from the UPS's battery.

- Press and hold the on/off/test button until the UPS begins beeping.
- Release the on/off/test button during the beeping to start the UPS.

Storage

Storage Conditions

Store the UPS covered and upright in a cool, dry location, with its battery fully charged. Before storing, charge the UPS for at least 4 hours. Disconnect any cables connected to the computer interface port to avoid unnecessarily draining the battery.

Extended storage

At -15 to +30 °C (+5 to +86 °F), charge the UPS's battery every 6 months

At +30 to +45 °C (+86 to +113 °F), charge the UPS's battery every 3 months.

Replacing the Battery

This UPS has an easy to replace hot-swappable battery.

Note: Please read the cautions in the APC Safety Guide.

Replacement Batteries

See your dealer or call the number in this manual for information on replacement battery kits. For 280 and 420 models, order RBC 2. For 650 models, order RBC 4.

Battery Replacement Procedure

Battery replacement is a safe procedure, isolated from electrical hazards. You may leave the UPS and loads on for the following procedure.

Note: Once the battery is disconnected, the loads are not protected from power outages.

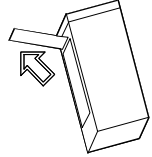

1. Lay the UPS on its left side. Remove the two screws holding on the battery door and open the door.

Note: It may be necessary to pull the battery door slightly toward the front of the unit in order to open the door fully.

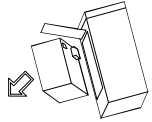

2. Gently pull out the battery by grasping the white tab.

3. Disconnect the two wires connecting the battery to the UPS. Loosen the wires by wiggling them while pulling straight back from the battery connector.

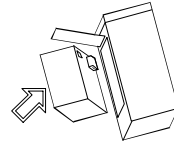

4. Connect the new battery in place of the old.

Note: Small sparks at the battery connections are normal during connection.

5. Place the new battery in the UPS. Use care to avoid pinching the wires.

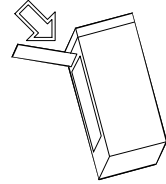

6. Close the battery compartment door and replace the screws.



7. Dispose of the old battery properly at an appropriate recycling facility or return it to the supplier in the packing material for the new battery. See the new battery instructions for more information.

Troubleshooting

Problem	Possible Cause	Solution
UPS will not turn on.	On/off/test button not pushed.	Press the on/off/test button to power the UPS and the loads.
	UPS input circuit breaker tripped.	Reduce the load on the UPS by unplugging equipment and reset the circuit breaker by pressing the plunger back in.
UPS will not turn on or off.	Computer interface problem.	Disconnect the computer interface. If the UPS now works normally, check the interface cable and the attached computer.
UPS operates on-battery even though normal line voltage is thought to exist.	UPS's input circuit breaker tripped.	Reduce the load on the UPS by unplugging equipment and reset the circuit breaker by pushing the plunger back in.
UPS beeps occasionally.	Normal UPS operation.	None. The UPS is protecting the load.
UPS does not provide expected back up time.	The UPS's battery is weak due to recent outage or is near the end of its service life.	Charge the battery. The UPS's batteries require recharging after an extended outage. Batteries age faster when put into service often and when operated at elevated temperatures. If the battery is near the end of its service life, consider replacing the battery even if the replace battery indicator is not yet lit.
On-line and overload indicators are flashing alternately.	The UPS was shutdown by PowerChute® plus software.	None. The UPS will restart automatically when utility power returns.
All indicators are flashing.	Internal UPS fault.	Do not attempt to use the UPS. Turn the UPS off and have it serviced immediately.
The UPS operates normally, but the site wiring fault indicator is lit.	Building wiring error such as missing ground or hot to neutral wire reversal.	Have a qualified electrician correct the building wiring.
On-line and on-battery indicators only are flashing	Internal UPS fault.	Do not attempt to use the UPS. Turn the UPS off and have it serviced immediately.
All indicators are off and the UPS is not operating.	The UPS is shutdown and the battery is discharged from an extended power outage.	None. The UPS will return to normal operation when the power is restored and the battery has a sufficient charge.
The replace battery light is illuminated.	Weak batteries.	Allow the batteries to recharge for at least 4 hours. If the problem persists after recharging, replace the batteries.
	Replacement batteries not connected properly.	Confirm the battery connections.
The overload light is illuminated or flashing	The UPS is overloaded.	Reduce the load on the UPS by unplugging equipment.

For Computer Interface Port Specifications, see the APC Website.

Declaration of Conformity		
Application of Council Directives:	89/336/EEC, 73/23/EEC, 92/31/EEC, 93/68/EEC, 91/157/EEC	
Standards to Which Conformity Declared:	EN55022, EN50082-1, EN50091, EN60950	
Manufacturer's Name and Address:	American Power Conversion 132 Fairgrounds Road West Kingston, Rhode Island, 02892, U.S.A -or- American Power Conversion (A. P. C.) b. v. Ballybritt Business Park Galway, Ireland -or- American Power Conversion Philippines Second Street Cavite FIPA Rosario, Cavite Philippines American Power Conversion (A. P. C.) b. v. Ballybritt Business Park Galway, Ireland -or- Uninterruptible Power Supply BP280IS, BP420IS, BP650IS, SU402INET, SU620INET	
Importer's Name and Address:	American Power Conversion (A. P. C.) b. v. Ballybritt Business Park Galway, Ireland -or- Uninterruptible Power Supply BP280IS, BP420IS, BP650IS, SU402INET, SU620INET	
Type of Equipment:	Uninterruptible Power Supply	
Model Numbers:	BP280IS, BP420IS, BP650IS, SU402INET, SU620INET	
Serial Numbers:	X9701 000 0000 — X9799 999 9999* X9801 000 0000 — X9899 999 9999* 1997, 1998	
Years of Manufacture:	1997, 1998	
Note:	Where X = B, O, W, P, or D	
We, the undersigned, hereby declare that the equipment specified above conforms to the above directives.		
Billsica, MA	1/19/97	Bill Burks Regulatory Compliance Engineer
Place	Date	
Galway, Ireland	1/19/97	Gerard Rutten Managing Director, Europe
Place	Date	

Service

If the UPS requires service *do not return it to the dealer!*

Follow these steps:

1. Use the **Troubleshooting** section of the **Quick Reference Guide** to eliminate common problems.
 2. Verify that no circuit breakers are tripped. A tripped circuit breaker is the most common UPS problem!
 3. If the problem persists, call customer service or visit the APC Internet Website (www.apcc.com).
- Note the model number of the UPS, the serial number, and the date purchased. A technician will ask you to describe the problem and try to solve it over the phone, if possible. If this is not possible the technician will issue a Return Merchandise Authorization Number (RMA#).
 - If the UPS is under warranty, repairs are free. If not, there is a repair charge.
4. Pack the UPS in its original packaging. If the original packing is not available, ask customer service about obtaining a new set.
 - Pack the UPS properly to avoid damage in transit. Never use Styrofoam beads for packaging. Damage sustained in transit is not covered under warranty.
 - Include a letter with your name, RMA#, address, copy of the sales receipt, description of the trouble, your daytime phone number, and a check (if necessary).
5. Mark the RMA# on the outside of the package
 6. Return the UPS by insured, prepaid carrier to the address given to you by Customer Service.

North & South America	Europe
APC 132 Fairgrounds Road West Kingston, Rhode Island 02892 USA 1-800-800-4APC/1-401-789-5735	APC Ballybritt Business Park Galway, Ireland 10800-702000 353-91-702020
Internet: http://www.apcc.com	
E-Mail: apctech@apcc.com	E-Mail: apceurtech@apcc.com

Specifications

	420 VA	620 VA
Acceptable input voltage	0 - 320 VAC	
Input voltage (on-line operation)*	165 - 283 VAC	
Output voltage *	208 - 253 VAC	
Input Over Current Protection	Resettable circuit breaker	
Frequency limits (on-line operation)	47 - 63 Hz (autosensing)	
Transfer time	4 ms typical, blackout response time	
Maximum load	420 VA 260 W	620 VA 390 W
On-battery output voltage	230 VAC	
On-battery frequency	50 or 60 Hz, ± 0.1 Hz; unless synchronized to utility during brownout	
On-battery waveshape	Stepped sine-wave	
Output Over Current Protection	Overcurrent and short-circuit protected, latching shutdown on overload	
Battery type	Spill proof, maintenance free, sealed lead-acid	
Typical battery life	3 to 6 years, depending on number of discharge cycles and ambient temperature	
Typical recharge time	2 to 5 hours from total discharge	
Operating temperature	0 to +40 °C (+32 to +104 °F)	
Storage temperature	-15 to +45 °C (+5 to +113 °F)	
Operating and storage relative humidity	0 to 95%, non-condensing	
Operating elevation	0 to +3,000 m (0 to +10,000 ft)	
Storage elevation	0 to +15,000 m (0 to +50,000 ft)	
Audible noise at 1 m (3 ft)	<45 dBA	
Size (H x W x D)	16.8 x 11.9 x 36.8 cm (6.6 x 4.7 x 14.5 in.)	
Weight - net (shipping)	7.30 (9.12) kg 16.108 (20.10) lb.	10.53 (12.34) kg 23.51 (27.21) lb.
Safety and approvals	VDE licensed to EN50091 and EN60950	
EMC certification	EN55022	
Electromagnetic immunity	IEC 801-2 level IV, 801-3 level III, 801-4 level IV	
* User-adjustable through PowerChute® (see software documentation)		