

# APC Symmetra RM

## Installation Manual

English

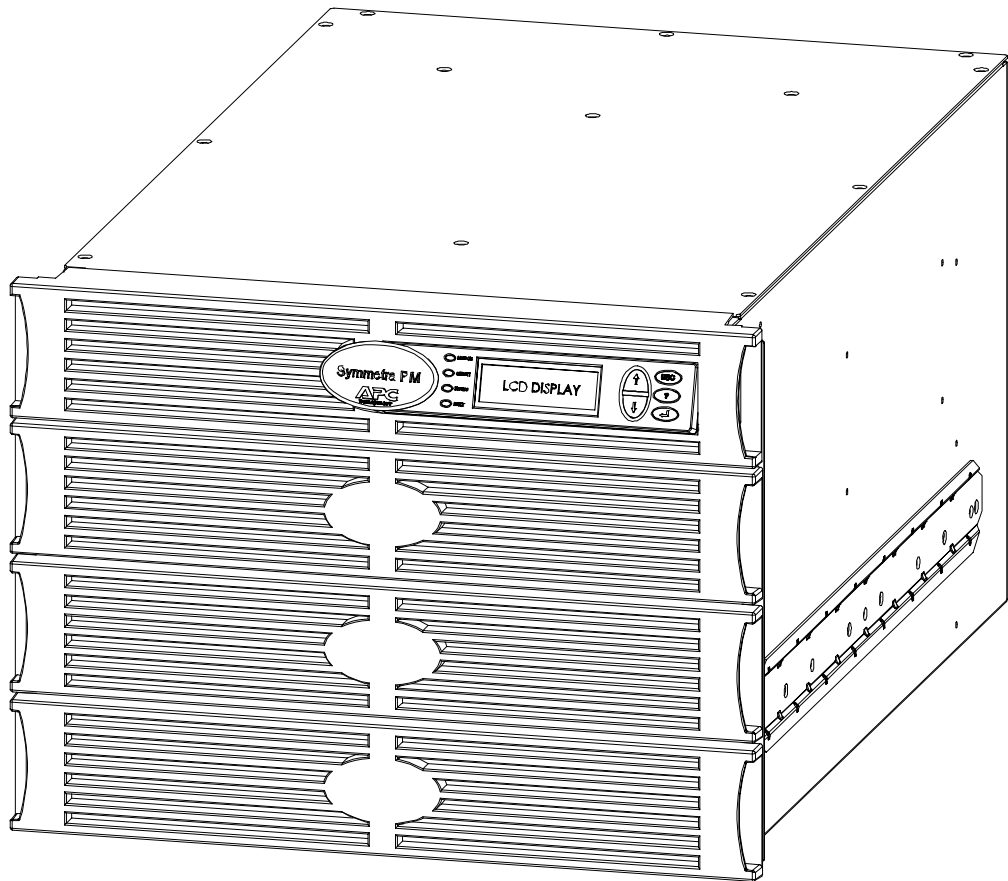

**APC**

[www.apcc.com](http://www.apcc.com)

## Limited Warranty

---

American Power Conversion (APC) warrants its products to be free from defects in materials and workmanship for a period of two years from the date of purchase, except in India where the period is one year for battery module(s). Its obligation under this warranty is limited to repairing or replacing, at its own sole option, any such defective products. To obtain service under warranty you must obtain a Returned Material Authorization (RMA) number from customer support (see *Service* in the SYMMETRA RM OPERATION MANUAL). Products must be returned with transportation charges prepaid and must be accompanied by a brief description of the problem encountered and proof of date and place of purchase. This warranty does not apply to equipment which has been damaged by accident, negligence, or misapplication or has been altered or modified in any way. This warranty applies only to the original purchaser who must have properly registered the product within 10 days of purchase.

EXCEPT AS PROVIDED HEREIN, AMERICAN POWER CONVERSION MAKES NO WARRANTIES, EXPRESSED OR IMPLIED, INCLUDING WARRANTIES OF MERCHANTABILITY AND FITNESS FOR A PARTICULAR PURPOSE. Some states do not permit limitation or exclusion of implied warranties; therefore, the aforesaid limitation(s) or exclusion(s) may not apply to the purchaser.

EXCEPT AS PROVIDED ABOVE, IN NO EVENT WILL APC BE LIABLE FOR DIRECT, INDIRECT, SPECIAL, INCIDENTAL, OR CONSEQUENTIAL DAMAGES ARISING OUT OF THE USE OF THIS PRODUCT, EVEN IF ADVISED OF THE POSSIBILITY OF SUCH DAMAGE. Specifically, APC is not liable for any costs, such as lost profits or revenue, loss of equipment, loss of use of equipment, loss of software, loss of data, costs of substitutes, claims by third parties, or otherwise. This warranty gives you specific legal rights and you may also have other rights which vary from state to state.

## Life Support Policy

---

As a general policy, American Power Conversion (APC) does not recommend the use of any of its products in life support applications where failure or malfunction of the APC product can be reasonably expected to cause failure of the life support device or to significantly affect its safety or effectiveness. APC does not recommend the use of any of its products in direct patient care. APC will not knowingly sell its products for use in such applications unless it receives in writing assurances satisfactory to APC that (a) the risks of injury or damage have been minimized, (b) the customer assumes all such risks, and (c) the liability of American Power Conversion is adequately protected under the circumstances.

Examples of devices considered to be life support devices are neonatal oxygen analyzers, nerve stimulators (whether used for anesthesia, pain relief, or other purposes), autotransfusion devices, blood pumps, defibrillators, arrhythmia detectors and alarms, pacemakers, hemodialysis systems, peritoneal dialysis systems, neonatal ventilator incubators, ventilators for both adults and infants, anesthesia ventilators, infusion pumps, and any other device designated as "critical" by the U.S.F.D.A.

Hospital grade wiring devices and leakage current may be ordered as options on many APC UPS systems. APC does not claim that units with this modification are certified or listed as Hospital Grade by APC or any other organization. Therefore these units do not meet the requirements for use in direct patient care.

Entire contents copyright © 2000 by American Power Conversion Corporation. All rights reserved.  
Reproduction in whole or in part without permission is prohibited.

APC and PowerChute are registered trademarks of American Power Conversion Corporation. All other trademarks are the property of their respective owners.

# Table of Contents

<b>Chapter 1: Safety Information .....</b>	<b>1</b>
Conventions Used in this Manual .....	1
Handling Safety.....	1
Electrical Safety .....	1
Deenergizing Safety .....	2
Battery Safety.....	2
Recycling of Batteries .....	3
Radio Frequency Interference .....	3
<b>Chapter 2: Basics .....</b>	<b>5</b>
About Your UPS .....	5
How To Contact APC .....	6
North America .....	6
Latin America, South America.....	6
Europe, Middle East, and Africa .....	6
Japan, Asia, Australia.....	6
Product Overview.....	7
Front View Component Identification.....	7
Rear View Component Identification.....	8
System Block Diagram.....	10
<b>Chapter 3: Installation .....</b>	<b>11</b>
Unpacking .....	11
Inspection .....	11
Contents.....	11
Placement .....	11
Installing the Symmetra RM .....	11
Position the Symmetra RM .....	11
Connect the Symmetra RM to its Power Source .....	13
Wire the Emergency Power Off (EPO) Switch .....	14
Install Modules Into the Symmetra RM Frame .....	15
Connect Equipment to the Symmetra RM.....	16
<b>Appendix A: Electrical Wiring Checklist.....</b>	<b>17</b>

# List of Figures

- Figure 1: Symmetra RM..... 5
- Figure 2: Front View of the Symmetra RM ..... 7
- Figure 3: Rear View of the Symmetra RM (200/208 Vac / L1-L2-G version shown)..... 8
- Figure 4: System Block Diagram ..... 10
- Figure 5: EPO Connection Option 1 ..... 15
- Figure 6: EPO Connection Option 2 ..... 15
- Figure 7: Bay Identification ..... 15
- Figure 8: Power Distribution Panels ..... 16

# CHAPTER 1: SAFETY INFORMATION

This Safety section contains important instructions that should be followed during installation and maintenance of the APC equipment and batteries. It is intended for APC customers who setup, install, relocate, or maintain APC equipment.

**Connection to the branch circuit (mains) must be performed by a Licensed Electrician. Installation and removal of the Power, Battery, and Intelligence modules must be performed by service personnel. Installation and removal of interface accessories must be performed by service personnel. Operation of the Symmetra RM can be performed by any individual with no previous technical experience.**

## Conventions Used in this Manual

---

This section defines the symbols used throughout this manual. Carefully read all information boxes and abide by the instructions.



The **WARNING** sign denotes a serious hazard. It calls attention to a procedure, practice, condition, or the like, which, if not correctly performed or adhered to, could result in injury to personnel.

---



The **CAUTION** sign denotes a hazard. It calls attention to an operating procedure, practice, or the like, which, if not correctly performed or adhered to, could result in damage to or destruction of all or part of the product.

---



The **NOTE** sign denotes important information. It calls attention to a procedure, practice, condition, or the like, which is essential to highlight.

---

## Handling Safety

---

- Be careful. Do not lift heavy loads without assistance.

⇒ <18 kg (<40 lb)



⇒ 32 – 55 kg (70 – 120 lb)



⇒ 18 – 32 kg (40 – 70 lb)

⇒ >55 kg (>120 lb)



- Equipment with casters is built to move on a smooth surface without any obstacles.
- Do not use a ramp inclined at more than 10°.
- This equipment is intended for installation in a temperature-controlled indoor area (see *Specifications* in the SYMMETRA RM OPERATION MANUAL), free of conductive contaminants.

## Electrical Safety

---

- Do not work alone under hazardous conditions.
- High short circuit current through conductive materials could cause severe burns.
- A licensed electrician is required to install permanently wired equipment.
- Check that the power cord(s), plug(s), and sockets are in good condition.
- To reduce the risk of electric shock when grounding cannot be verified, disconnect the equipment from the AC power outlet before installing or connecting to other equipment. Reconnect the power cord only after all connections are made.
- Do not handle any kind of metallic connector before the power has been removed.



- Use one hand, whenever possible, to connect or disconnect signal cables to avoid a possible shock from touching two surfaces with different electrical grounds.
- Connect the equipment to a three wire AC outlet (two poles plus ground). The receptacle must be connected to appropriate branch circuit/mains protection (fuse or circuit breaker). Connection to any other type of receptacle may result in a shock hazard.
- The protective earth conductor for the Symmetra RM carries the leakage current from the load devices (computer equipment). Therefore, the size of the conductor must be at least as large as the wire required by IEC 950. IEC 950 states the following nominal cross-sectional areas:

Cross-sectional Area		Rated Current Range
(mm <sup>2</sup> )	AWG	(A)
2.5	12	17 – 25
6	8	33 – 40
10	6	41 – 63
16	4	64 – 80

- An insulated grounding conductor that is identical in size, insulation material, and thickness to the grounded and ungrounded branch-circuit supply conductors, except that it is green with or without a yellow stripe is to be installed as part of the branch circuit that supplies the Symmetra.
- The grounding conductor described above is to be grounded to earth at the service equipment, or if supplied by a separately derived system, at the supply transformer or motor-generator set.
- The attachment-plug receptacles in the vicinity of the unit or subsystem are all to be of a grounding type, and the grounding conductors serving these receptacles are to be connected to earth ground at the service equipment.

## Deenergizing Safety

---

- To remove all power from the Symmetra RM (Total Power Off), the following series of events must occur in the order listed:
  1. Set the system enable switch to stand by .
  2. Set the input circuit breaker to stand by .
  3. Remove the battery modules.
  4. Disconnect the external battery pack (if provided).
  5. Disconnect the Symmetra RM from the mains/circuit branch.
- Use of this equipment in life support applications where failure of this equipment can reasonably be expected to cause the failure of the life support equipment or to significantly effect its safety or effectiveness is not recommended.

## Battery Safety

---



- **Risk of electrical shock and energy hazard (120 V, 5 ampere-hour battery). Before replacing batteries, remove conductive jewelry such as chains, wrist watches, and rings. High short circuit current through conductive materials could cause severe burns.**
- **Do not dispose of batteries in a fire. The batteries may explode.**
- **Do not open or mutilate batteries. They contain electrolyte that is toxic and harmful to the skin and eyes.**



**Batteries must be recycled.** Deliver the battery to an appropriate recycling facility or ship it to the supplier in the new battery's packing material. See the new battery instructions for more information.

- Store the battery module(s) in a cool ambient temperature of < 25 °C.
- When replacing batteries, use only the same APC battery pack (SYBT2).

## Recycling of Batteries

---

See your dealer or *Replacing Modules* in the SYMMETRA RM OPERATION MANUAL, for information on replacement battery kits and battery recycling.



- **Do not install the battery module(s) in the frame until you are ready to power up the Symmetra RM. Failure to so can result in a deep discharge of the batteries, which may cause permanent damage.**
  - **Store the battery module(s) in a cool ambient temperature of < 25 °C.**
- 

## Radio Frequency Interference

---

This equipment has been tested and found to comply with the limits for a Class A digital device, pursuant to part 15 of the FCC Rules. These limits are designed to provide reasonable protection against harmful interference when the equipment is operated in a commercial environment. This equipment generates, uses, and can radiate radio frequency energy and, if not installed and used in accordance with the instruction manual, may cause harmful interference to radio communications. Operation of this equipment in a residential area is likely to cause harmful interference in which case the user will be required to correct the interference at his own expense.

Shielded signal cables must be used with this product to ensure compliance with the Class A FCC limits.





## About Your UPS

The Symmetra RM is a high-performance, uninterruptible power system in a “power array” configuration, designed to power high availability servers and other sensitive electronic equipment. It provides conditioned, reliable AC power to connected equipment, and provides protection from power blackouts, brownouts, swells, sags, surges, and interference. The Symmetra RM is comprised of a frame and a variable set of modules. A system can be configured to deliver a maximum output of 6 kVA N+1 redundant or 6 kVA non-redundant.

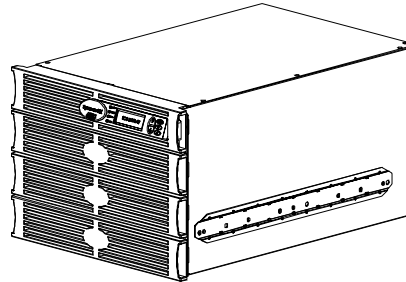

Figure 1: Symmetra RM

The Symmetra RM is modular in design and contains the following modular components:

- Power Processing System—called the power module
- Battery Source—called the battery module
- User interface—called the PowerView RM

Table 1: End Item Configurations

Complete System— End Item SKU	Battery Modules	Power Modules	Nominal Input Voltage	Nominal Output Voltage
SYH2K6RMT	1	1	208/240	208/240
SYH4K6RMT	2	2	208/240	208/240
SYH6K6RMT	3	3	208/240	208/240
SYH2K6RMI	1	1	230	230
SYH4K6RMI	2	2	230	230
SYH6K6RMI	3	3	230	230
SYH2K6RMT-P1	1	1	208/240	120/208
SYH4K6RMT-P1	2	2	208/240	120/208
SYH6K6RMT-P1	3	3	208/240	120/208

Module	End Item SKU
Redundant Intelligence	SYRIM3
Main Intelligence	SYMIM3
Battery	SYBT2
Power	SYPM2KU
Description	Option End Item SKU
Step-Down Transformer 208 to 120 V	SYTF2
PDU plate with 8 IEC-C13 and 2 IEC-C19 receptacles	SYPD1
PDU plate with 2 L6-20 and 1 L6-30 receptacles	SYPD2*
* PDU plate can connect to other Matrix PDU options	

# How To Contact APC

---

Internet <http://www.apc.com/support>

## **North America**

Phone 1.800.800.4272  
Fax 1.401.788.2743  
Email [apctech@apcc.com](mailto:apctech@apcc.com)

## **Latin America, South America**

Argentina.....0800.9.APCC (0800.9.2722)	Mexico..... 95.800.804.4283
Brazil .....0800.12.72.21	Uruguay..... 000.413.598.2139
Colombia .....980.15.39.47	Venezuela..... 8001.2544

## **Europe, Middle East, and Africa**

Phone.....+353 91 702020	Email..... <a href="mailto:apceurtech@apcc.com">apceurtech @ apcc.com</a>
Fax.....+353 91 755275	Web support.... <a href="http://www.apc.com/support">www.apc.com/support</a> - eSupport

Ireland.....1 800 702000 x 2045	Italy..... 800 874 731
Austria .....0800 29 64 80	Luxembourg.....0800 2091
Belgium .....0800 15063	Norway..... 800 11 632
Czech Republic.0800 102063	Poland .....00800 353 1202
Denmark .....800 18 153	Portugal..... 0800 853 182
Finland.....9800 13 374	Russia.....007 095 9167166 (toll number)
France .....0800 906 483	South Africa..... 0800 994206
Germany .....0800 180 1227	Spain .....900 95 35 33
Greece.....00800 353 12206	Sweden.....020 795 419
Holland .....0800 0224655	Switzerland .....0800 556177
Hungary .....06800 12221	Turkey.....0800 35390275
Israel.....177 353 2206	United Kingdom.....0800 132990

## **Japan, Asia, Australia**

Australia, New Zealand.....	+61 2 9955 9366, 1-800-652-725
Singapore, Thailand, Vietnam.....	+65 398 1000
Malaysia.....	+60 3 756 8786
Indonesia.....	+62 21 6500813
China.....	+86 10 8529 9888
Hong Kong.....	+85 2 2834 5001
Taiwan.....	+88 622 755 1945
India, Nepal, Sri Lanka, Bangladesh, Maldives.....	+91 44 433 1124
Japan.....	+81 3 5434 2021
Korea.....	+82 2 501 6492
Philippines.....	+63 2 813 2662

## Product Overview

### Front View Component Identification

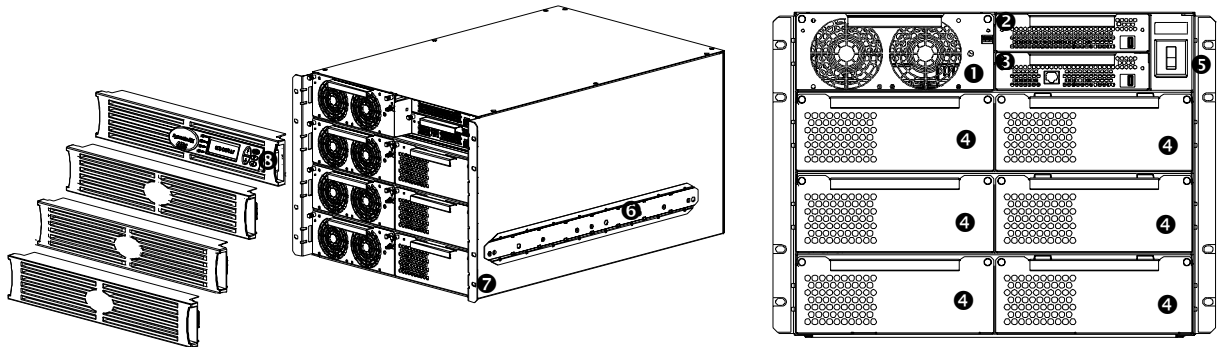

Figure 2: Front View of the Symmetra RM

**Power Module(s) ❶:** The Symmetra RM can support between one and four power modules. Each module provides 2 kVA/1.4 KW power.

**Redundant Intelligence Module ❷:** The redundant intelligence module (RIM) is a backup version of the main intelligence module(MIM). It provides redundancy in the event of a MIM failure or while a MIM is being replaced.

**Main Intelligence Module ❸:** The main intelligence module (MIM) is the “computer” of the Symmetra RM. It gathers and processes data, including monitoring the condition of each of the modules.

**Battery Module(s) ❹:** Each battery module contains multiple batteries housed in the enclosure. The Symmetra RM can house up to six battery modules (three on the right and three in the lower bays on the left).

**System Enable Switch ❹:** The system enable switch regulates power to the intelligence modules. It does not power the load. When the switch is in the On position, the Symmetra RM enters the load-disconnect operating mode. When the switch is in the Stand By position, the intelligence modules are disconnected from the utility (mains) voltage.



The load is not powered until the Power the Load command is entered into the PowerView RM interface.

**Mounting Rails ❻:** The attached mounting rails (one on either side) support the Symmetra RM when it is mounted in a rack.

**Mounting Bracket ❼:** The mounting bracket allows you to secure the Symmetra RM in the rack.

**PowerView RM ❸:** The PowerView RM is the primary user interface for the Symmetra RM.

## Rear View Component Identification

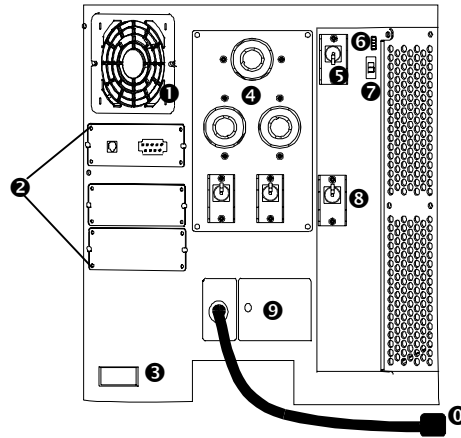

Figure 3: Rear View of the Symmetra RM (200/208 Vac / L1-L2-G version shown)

**System Fan ❶:** The system fan can be replaced in the field. Refer to *Replacing the System Fan*, in the SYMMETRA RM OPERATION MANUAL, for instructions.

**Accessory Ports ❷:** APC manufactures a set of auxiliary user interface accessories. The Symmetra RM contains a total of three accessory ports. The top slot is preloaded with the SYCC card that provides computer and battery ports. Two unoccupied accessory slots is provided. The Symmetra RM also includes a Web/SNMP Management Card for accessing data via a network. Other accessory options are available, including:

- Out-of-Band Monitoring Card (formerly named CallUPS) initiates telephone notification of power event
- Environmental Monitoring Card (formerly named MeasureUPS) monitors environmental conditions
- Control-UPS control and monitor via modem



---

Use only accessory devices labeled “Symmetra compatible.”

---

**External Battery Cabinet Connector ❸:** Connect an External Battery Cabinet to the Symmetra RM using this connector. The Symmetra RM can connect to a maximum of seven external battery cabinets in a daisy-chain fashion.

**Power Distribution Panel (PDU) ❹:** The type of power panel depends on the voltage range of the Symmetra RM. Figure 3 shows a Symmetra RM with a 200/208 Vac (L1-L2-G) power panel. It contains one L6-30 and two L6-20 receptacles. The 220/230/240 Vac (L1-N-G) power panel contains eight IEC C13 and two IEC C19 receptacles. Figure 8, page 16, shows the two PDU panels. The PDU panel can be changed in the field by a qualified technician or electrician.

**Input Circuit Breaker ❺:** The input circuit breaker, located at the back of the frame, protects the Symmetra RM from extreme overloads. When switched to Stand By the Symmetra RM is disconnected from incoming utility voltage. When switched to the On position, power flows from the utility source into the Symmetra RM. Under normal operating conditions, the input circuit breaker always remains in the On position.

**Emergency Power Off (EPO) Switch Connection ❻:** Use this connection to wire the Symmetra RM to an emergency power off switch located away from the unit. This switch shuts off power to Symmetra RM and prevents the unit from operating on-battery. The terminal connections for the EPO switch are physically isolated from the primary circuitry of the Symmetra RM. See *Wire the Emergency Power Off (EPO) Switch*, page 14, for wiring instructions.



---

**EPO wiring must be installed by a qualified electrician only.**

---

**Input Voltage Selection Switch ⑦:** Set this switch to the appropriate setting, either 200/208 (L1-L2-G) or 220/230/240 (L1-N-G) before powering up the Symmetra RM.

*Products rated 200/208* are typically installed in North America (208 V, phase to phase, grounding conductor) and Japan (200V, phase to phase, grounding conductor).

*Products rated 2020/230/240* are typically installed in the rest of the world (220 V, 230 V, or 240 V, phase to neutral, protective earth). These products must be hard wired to the input power.

**Maintenance Bypass Switch ⑧:** When switched to the On position, the maintenance bypass switch bypasses the Symmetra RM, and causes the load equipment to be powered directly from utility power. When it is switched to the Off position, utility power flows into the Symmetra RM, and conditioned power is delivered to the load equipment. Under normal operating conditions, the maintenance bypass switch remains in the Off position.



The load equipment is unprotected when the maintenance bypass switch is in the On position.

---

**Input Wiring Access Panels ⑨:** Provides access to wiring terminal blocks for input wiring. The 200/208 (L1-L2-G) version must be hard wired if the load is greater than 5 kVA. The 220/230/240 (L1-N-G) version must always be hard wired.

**Input Power Cord ⑩ [on 200/208 (L1-L2-G) versions only]:** The 200/208 (L1-L2-G) version can use the line cord to connect to the power source if the load is less than 5 kVA. If the load is greater than 5 kVA, the unit must be hard wired to the power source. The 220/230/240 (L1-N-G) version must always be hard wired.

# System Block Diagram

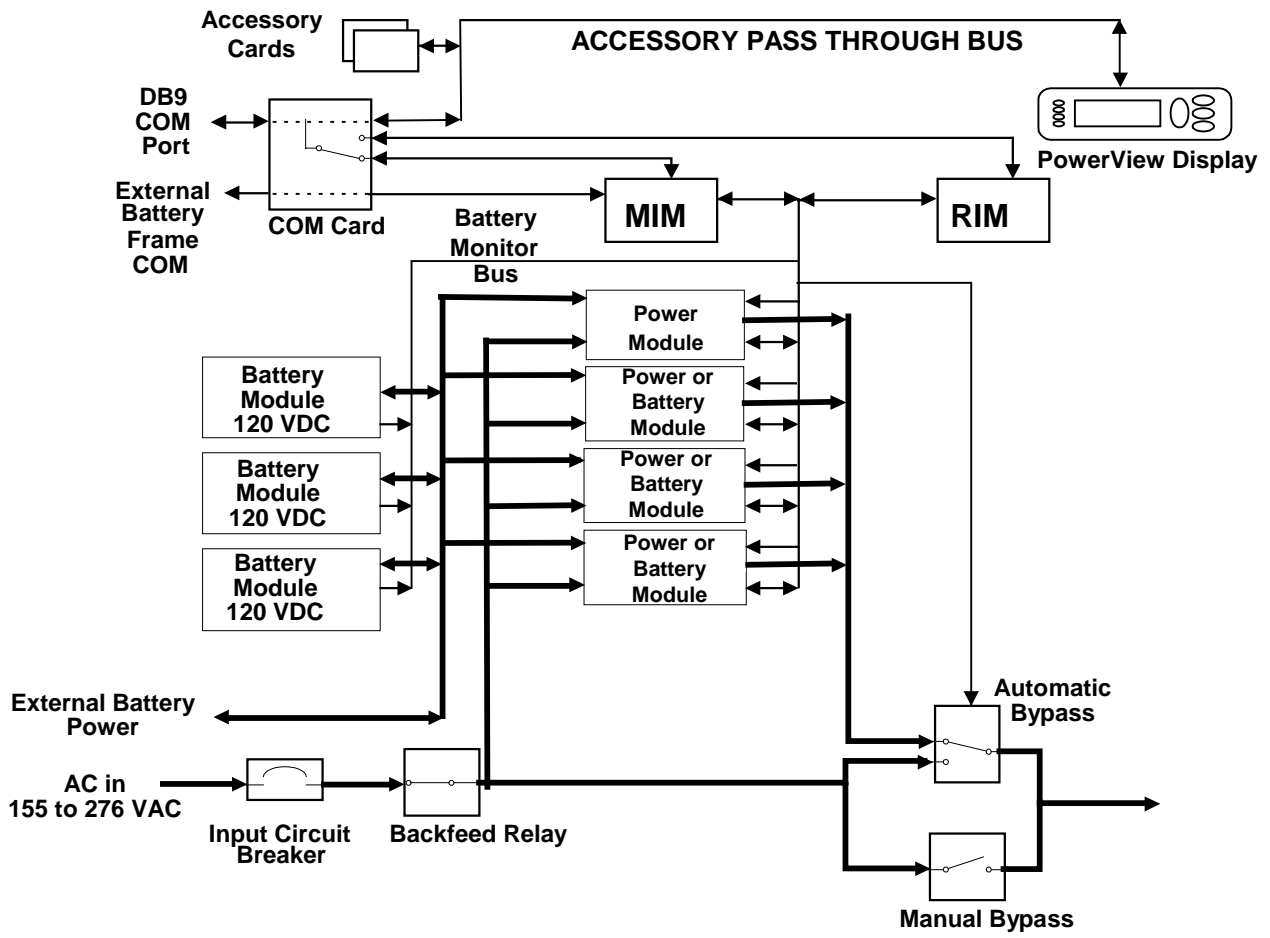

Figure 4: System Block Diagram

## Unpacking

APC has taken care to design robust packaging for your product. However, accidents and damage may occur during shipment.

### Inspection

Inspect the UPS upon receipt. Notify the carrier and dealer if there is damage. The packaging is recyclable; save it for reuse or dispose of it properly.

### Contents

The shipping package contains the UPS, one PowerView display bezel, three blank bezels, the mounting rail kit (containing the mounting rails, and hardware), one blank panel kit (containing five blank panels, screws and instructions), and a literature kit.

### Placement

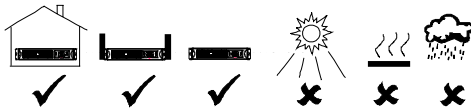

The Symmetra RM is designed for use in a data center or other office environment. Install it in a protected area that is free of excessive dust, corrosion, conductive contaminants, and has adequate air flow. Do not operate the UPS where the temperature and humidity are outside the specified limits.



**Changes or modifications to this unit not expressly approved by the party responsible for compliance could void the warranty.**

## Installing the Symmetra RM

Installing the Symmetra RM is a five-step process:

1. Position the Symmetra RM where it will be used. (This step includes mounting it in a rack if desired.)
2. Connect the Symmetra RM to its power source.
3. Wire the Emergency Power Off (EPO) switch.
4. Install modules into the Symmetra RM frame.
5. Connect equipment to the Symmetra RM.

This section describes each step in detail.

### Position the Symmetra RM



**Do not install the battery module(s) in the frame until you are ready to power up the Symmetra RM. Failure to do so can result in a deep discharge of the batteries, which may cause permanent damage.**

Mounting rails are included with the Symmetra RM. The rails support the unit in the rack and provide adequate air flow.



The Symmetra RM requires two people to install due to its weight.

## Determine the Location of the Symmetra RM in the Rack

1. Select a location for the Symmetra RM in your NetShelter enclosure or other 19-inch (46.5 cm) rack.



**Select a location with adequate air flow that is free from excessive dust. Ensure that the air vents on the sides of the Symmetra are not blocked.**

- The Symmetra RM is heavy. Select a rack location sturdy enough to handle the weight. Mount the unit at or near the bottom of the rack.
- Do not operate the unit where temperature or humidity are outside the limits listed in *Specifications* in the SYMMETRA RM OPERATION MANUAL.
- The Symmetra RM occupies a space of 8U. Some racks have tick marks to indicate the U-spaces.

2. Prepare the rack holes, if necessary. Racks with threaded holes require no preparation.

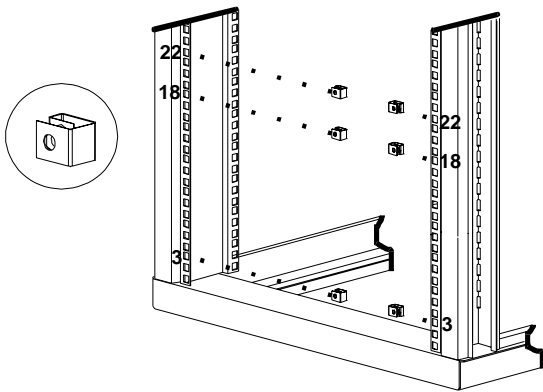

Locate the designated U-space and, counting from the bottom, mark holes 3, 18, and 22 on each front post.

If your rack has round holes, insert clip nuts (provided) into the marked holes.

If your rack has square holes, insert either clip nuts or cage nuts into the marked holes (cage nut shown).

These nuts will support the ornamental screws that attach the unit to the rack.

## Install the Mounting Rails in the Rack

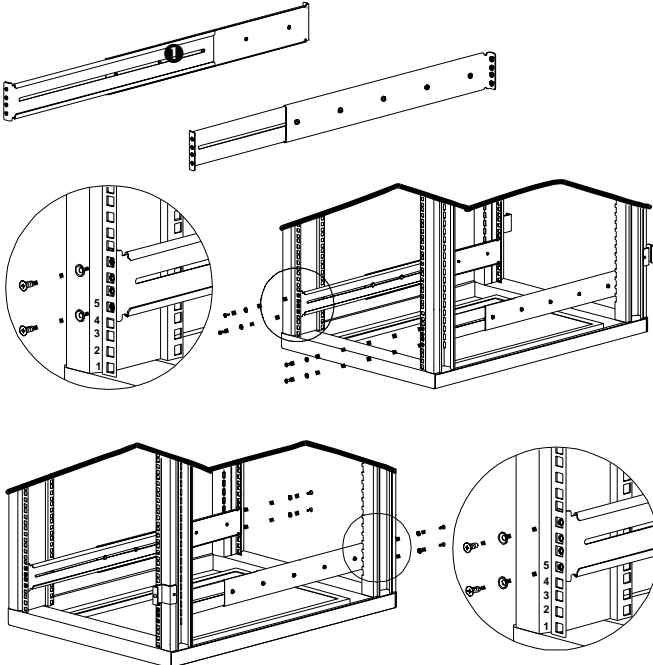

1. Loosen the three (3) screws ❶ that hold the rails together so that the rails can slide outward. Do not detach the rails.

2. Align the bottom hole on the mounting rail with the fifth hole (counting from the bottom) in the U-space. Use the flat, Phillips head screws (10-32) and conical washers to attach the front rail to the rack.

Expand the rails so that it spans from the front rack post to the back rack post.

3. Attach the rail to the back rack post using the same hardware (10-32 flat head screws and conical washers) used in step 2. Repeat the process for the other rails.

4. Tighten the three (3) screws, loosened in step 1, to secure the rails.



## Install the UPS into the Rack

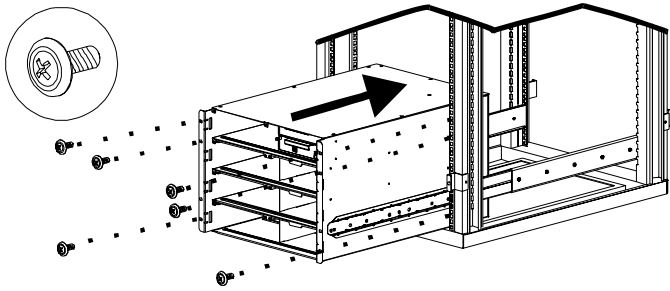

1. With two people supporting the Symmetra RM, one on each side, carefully align the cleats on the sides of the unit with the grooves on the mounting rails. Slide the unit into the rack completely.
2. Use the six (6) ornamental screws, supplied with the unit, to attach the mounting brackets to the rack post.

## Connect the Symmetra RM to its Power Source

**200/208/240 Vac (L1-L2-G) Symmetra RM:** The input power can be supplied in two ways: the attached line cord can be plugged into an appropriate outlet; or the power can be hard wired. Use the line cord if the load is  $\leq 5$  kVA. If the load is greater than 5 kVA you must hard wire the input power.

**220/230/240 Vac (L1-N-G) Symmetra RM:** The input power must be hard wired.

### How to Connect the Input Line Cord



If your Symmetra RM is configured for 200/208 Vac (L1-L2-G) and has a load of 5 kVA or less, use the line cord to power the Symmetra RM. No wiring is necessary.

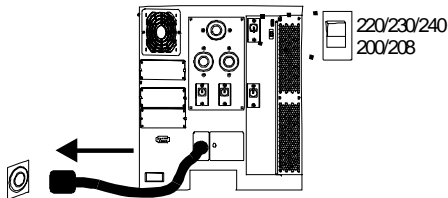

1. Set the input select switch to 200/208 (L1-L2-G).
2. Plug the standard 208 Vac L6-30 power cord into a 30 Amp 208 Vac outlet.

### How to Hard Wire the Symmetra RM



**Verify that all incoming line voltage (utility power) and low voltage (control) circuits are de-energized, and locked out before installing cables or making connections, whether in the junction box or to the Symmetra RM.**

**Verify that the battery modules have not been installed in the Symmetra RM. If battery module(s) have been installed, remove them before installing any wiring.**



**Only an authorized electrician should install all power and control wiring, according to national and local regulations.**



Hard wire the input power on all 220/230/240 Vac (L1-N-G) units and on any 200/208 (L1-L2-G) unit with a load greater than 5 kVA.

Use flexible metal conduit to make maintenance and service easier.

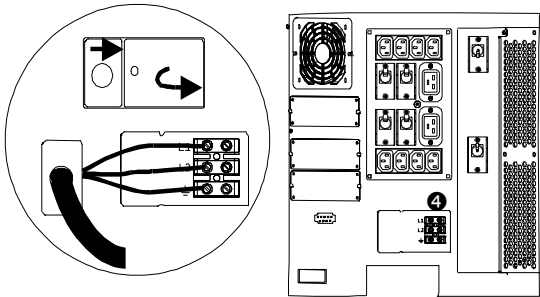
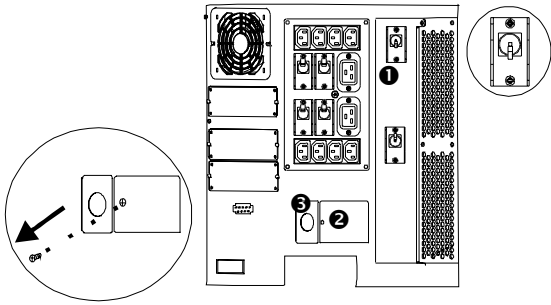

1. Make sure the main circuit breaker **1**, located on the rear panel, is in the OFF position.
2. Select the appropriate wire size and connectors, according to local codes. For most applications, #10 AWG (5 sq. mm) wire should be sufficient.
3. Remove the input wiring access door by unscrewing the single screw that holds the access panels in place. The input wiring terminal **2** is located on the rear panel of the Symmetra RM.
4. Use a screwdriver or any hard object to detach the circular knockout in the wire input plate **3**. You may need to use pliers to fully detach the knockout.
5. Feed the wire cable through the hole on the wire input plate. Using a threaded lock nut, fasten the plate to the selected cable or conduit connector.
6. Use a knife to strip off the plastic on the end of the cable to expose the copper wire. Strip all three wires.
7. Use a flat head screwdriver to connect the wires to the terminal block **4**. Loosen the screw, then feed the copper wire into the terminal block and tighten the screw. Connect the protective earth ground to the terminal block at the position marked with the ground symbol. Connect the three wires.
8. Reconnect the wire input plate. Align the plate, position it into the grooves and slide it to the left.
9. Inspect the connections and location of the excess wires before installing the access door.
10. Replace the access door and fasten with the screw (removed in step 3).

Once the electrician is finishing wiring the unit, complete the checklist in *Appendix A: Electrical Wiring Checklist*, page 17, for verification.

## Wire the Emergency Power Off (EPO) Switch

The Symmetra RM provides an emergency power switch connection that controls electrical power to the unit. When this switch is turned on (or enabled), electrical power to the unit is turned off and the system will not switch to on-battery operation. You must physically reset the system enable switch on the front of the Symmetra RM to restart the unit.



**Use only a qualified electrician to install the EPO wiring.**

The EPO circuit is considered a Class 2 (UL and CSA standards) and SELV (IEC standard) circuit.

**Class 2 Circuit:** Used in North America by UL and CSA. It is defined in the National Electrical Code (NFPA 70, Article 725) and in the Canadian Electrical Code (C22.1, Section 16).

**SELV Circuit:** Used in Europe by IEC; acronym for “safety extra low voltage.” A SELV circuit is isolated from primary circuitry through an isolating transformer and designed so that under normal conditions, the voltage is limited to 42.4 V peak or 60 V dc.

Both Class 2 and SELV circuits must be isolated from all primary circuitry. Do not connect any circuit to the EPO terminal block unless it can be confirmed that the circuit is SELV or Class 2. If there is a question, use a contact closure switch.

Use one of the following cable types to connect the Symmetra RM to the EPO switch:

- CL2                      Class 2 cable for general use.
- CL2P                    Plenum cable for use in ducts, plenums, and other spaces used for environmental air.
- CL2R                    Riser cable for use in a vertical run in a shaft of from floor to floor.
- CL2X                    Limited use cable for use in dwellings and for use in raceway.

**For installation in Canada:** Use only CSA Certified, type ELC (extra-low voltage control cable).

**Connection Option 1**

An electrician must connect 1 to 2. Then, both 3 and 4 must be connected to a normally open (NO) switch contact.

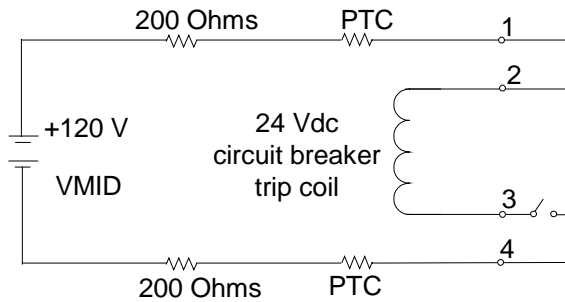

**Figure 5: EPO Connection Option 1**

**Connection Option 2**

An electrician must connect the 12 Vdc source and a normally open (NO) switch contact to 2 and 3.

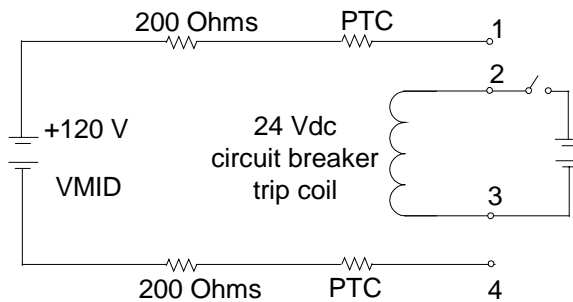

**Figure 6: EPO Connection Option 2**

**Install Modules Into the Symmetra RM Frame**

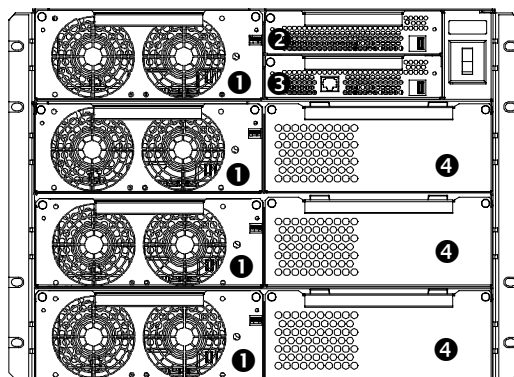

- ❶ = Power Module
- ❷ = Redundant Intelligence Module
- ❸ = Main Intelligence Module
- ❹ = Battery Module

**Figure 7: Bay Identification**

The intelligence modules are shipped in the Symmetra RM frame. After the frame is installed in the rack you must install the power and battery modules into the frame.



**Install battery modules just prior to running the Symmetra RM. The battery modules discharge slowly when loaded prematurely and can be damaged permanently.**



Each battery module weighs 21.8 kg (48 lbs). Two people are required to install or remove battery modules.

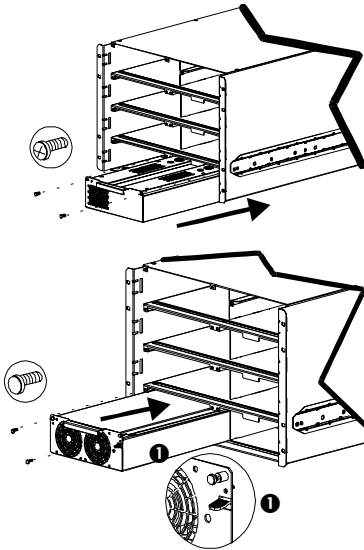

**Battery Module:** With one person on either side of the battery module, lift the module, and slide it completely into the frame to engage the internal electrical connector. The top of each battery module has a tab to align the module connector with the connector inside the bay. This tab ensures that only battery modules will fit into the bay.

Tighten the two (2) screws to secure the module.

Position battery modules in the bays on the right before filling bays on the left.

**Power Module:** Lift the power module, and slide the module into a bay until flush with frame to engage the internal connector. The side of the power module has a lever ❶ to help align the connector on the module with the connector inside the bay. It also locks the power module in place.

Tighten the two (2) screws to secure the module.



Install cover plates, included with the unit, over any unused bays.

### Connect Equipment to the Symmetra RM

Power is distributed to the connected equipment via the power distribution panel (PDU) on the rear panel of the Symmetra RM. Labeling on the rear panel indicates the circuit breaker/outlet groups.

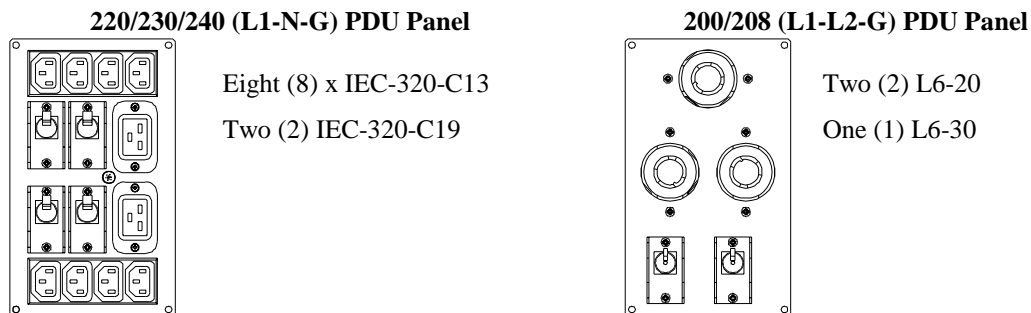

**Figure 8: Power Distribution Panels**

- Use your equipment's power cord to connect to the UPS.
- Turn on all connected equipment (the equipment will not be powered until the Symmetra RM is turned on).
- Add accessories for the accessories slot. See the literature accompanying the accessory for details.



This UPS is equipped with an accessory slot. See the APC website ([apcc.com](http://apcc.com)) for available accessories.

If a standard accessory is installed on this UPS, follow the installation instructions included with the accessory.

## APPENDIX A: ELECTRICAL WIRING CHECKLIST

Complete this checklist to ensure that the Symmetra RM has been wired properly.



**Ensure that all switches (system enable, maintenance bypass, input circuit breaker, and bypass circuit breaker) are in the Off or Stand By position. Turn off or unplug all equipment connected to the Symmetra RM.**

**Ensure that the input voltage selection switch is in the appropriate position.**

1. Apply power to the system input. Measure the voltage at the input terminal block. Record the measured voltages:

**L1-L2 for 200/208 Vac** \_\_\_\_\_

*OR*

**L1-Neutral for 220/230/240 Vac:** \_\_\_\_\_



**The measured voltage must be between 184 and 265 V. If it is not, do not continue! Verify the wiring from the power source to the input wiring connections. Repeat step 1.**

2. Connect the PowerView display bezel.

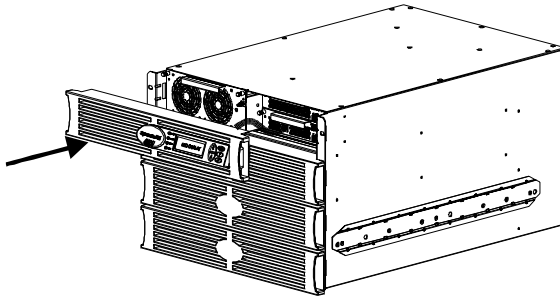

3. Switch the input circuit breaker, then switch the system enable switch on.



The system will make some clicking sounds as it powers up, and may display fault messages on the PowerView display. Disregard the messages at this time.

4. Press the escape key on the display until the top level menu screen appears. Select "Status." Pressing the enter key opens the voltage status screen, shown below.

Vin	Vout	Iout
237.0	0.0	0.0A



The fault light on the display may remain on. Disregard this visual indicator at this time.

5. Record input voltages below and compare the values with the measured voltages from step 1. If the two measurements are significantly different, contact APC Symmetra technical support.

**Vin 1:** \_\_\_\_\_

6. Switch the maintenance bypass switch on.



Disregard any LED indicator or fault messages on the PowerView.

---

Record the output voltage, below, and compare the value with Vin 1 from step 5. If the two measurements are significantly different, contact APC Symmetra technical support.

**Reported Output Voltage: Out** \_\_\_\_\_ **V** \_\_\_\_\_ **Hz**

7. Test the EPO switch. The system enable switch should physically move to the Stand By position, and the system should shut down completely. If this does not occur, check the connections and the EPO switch to ensure that they are installed and functioning properly.

8. Successful completion of steps 1 through 7 indicate that the system wiring is properly installed. Turn off breakers and switches and shut down input power to the system. Reinstall all wiring access panels on the frame.

**Electrical Installation Completed by:** \_\_\_\_\_  
\_\_\_\_\_  
\_\_\_\_\_