

Rack Power Distribution Unit—AP7551

General Information

Description

This booklet provides information on installing and operating AP7551, a basic Rack Power Distribution Unit (PDU).

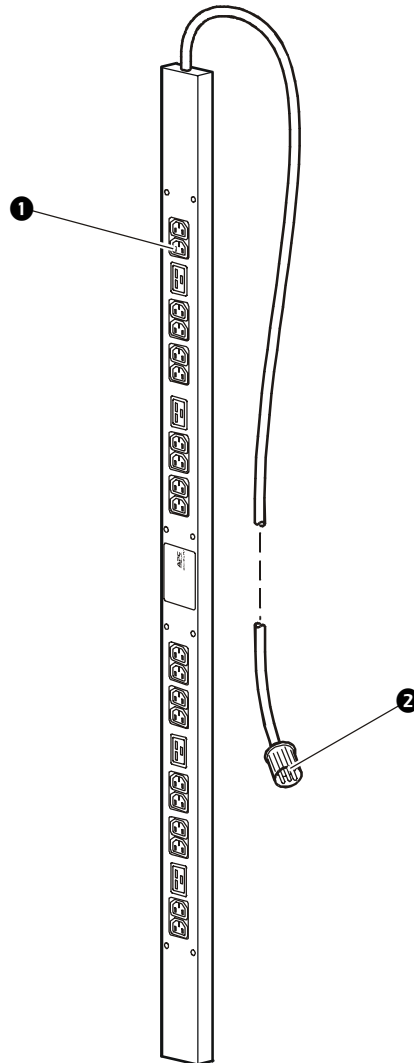

- ❶ 20 IEC 320 C13; 4 IEC 320 C19 outlets
- ❷ IEC 309 plug

Inventory

Quantity	Item
2	Cord retention tray (with 8 flat-head screws and 24 wire ties)
2	Mounting brackets (with 4 flat-head screws)
1	Basic and Metered PDU <i>Utility</i> CD
1	Warranty registration card

Translations

This manual is available in English on the enclosed CD.

Dieses Handbuch ist in Deutsch auf der beiliegenden CD-ROM verfügbar.

Ce manuel est disponible en français sur le CD-ROM ci-inclus.

Questo manuale è disponibile in italiano nel CD-ROM allegato.

ИНСТРУКЦИЯ ПО ИСПОЛЬЗОВАНИЮ НА РУССКОМ ЯЗЫКЕ ПРИЛАГАЕТСЯ НА ДИСКЕ (CD).

Instrukcja Obsługi w języku polskim jest dostępna na CD.

Este manual está disponible en español en el CD-ROM adjunto.

Bu kullanım kılavuzunun Türkçe'si, ilişikte gönderilen CD içerisinde mevcuttur.

Receiving inspection

Inspect the package and contents for shipping damage, and make sure that all parts were sent. Report any damage immediately to the shipping agent, and report missing contents, damage, or other problems immediately to APC or your APC reseller.

Please recycle



The shipping materials are recyclable. Please save them for later use, or dispose of them appropriately.

How to Install the Rack PDU

Attach the cord retention trays

Attach the cord retention trays to the Rack PDU, using four flat-head screws (provided) per tray.

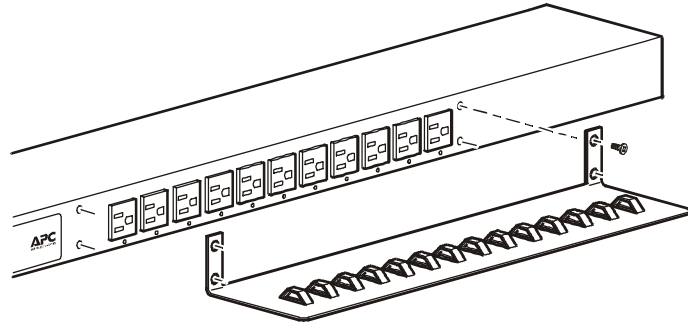

Attach cords to the tray

Attach a cord to the tray by looping the cord and securing it to the tray, using a wire tie (provided).

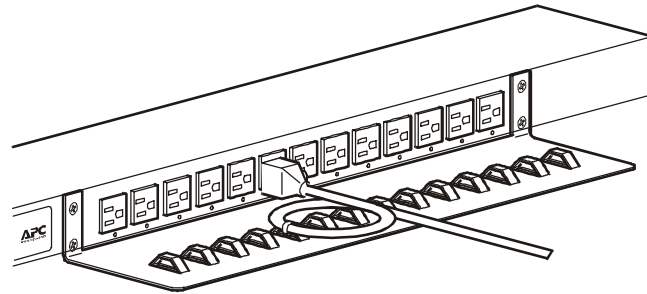

Note

Each cord must be secured to the tray so that you can unplug it from the Rack PDU without removing the wire tie.

Mounting options

You can install the Rack PDU in one of two ways: using toolless mounting pegs (provided) or the mounting brackets (provided).

- To install the Rack PDU using the toolless mounting method, install it in the rear of the NetShelter VX Enclosure, in the cable channel directly behind the rear vertical mounting rails.
- To install the Rack PDU using the mounting brackets, install it on a vertical mounting rail on your rack or enclosure.

Toolless mounting

1. Slide the mounting pegs into the holes located in the channel in the rear panel of the enclosure.
2. Snap the Rack PDU into place by pushing it downward until it locks into position.

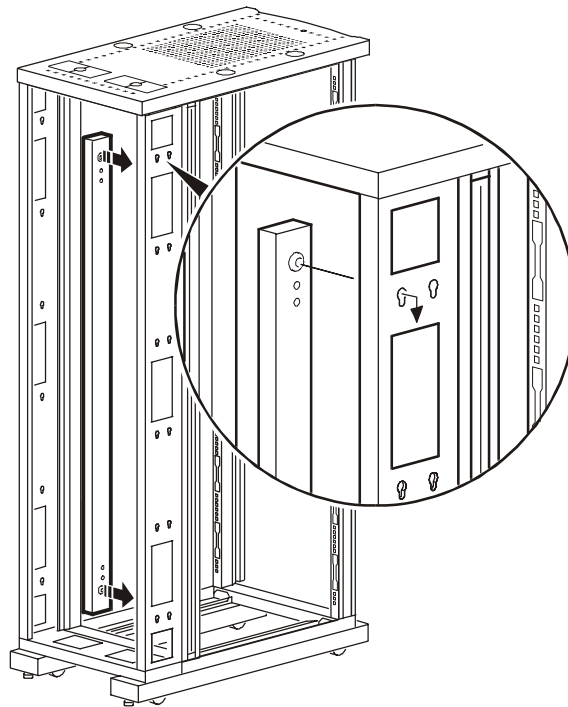

Note

You can mount two Rack PDUs on one side of the enclosure by using the toolless mounting method.

Bracket-mounting

To mount the Rack PDU vertically in a NetShelter[®] or any standard EIA-310 rack or enclosure:

1. Attach the vertical-mounting brackets to the Rack PDU.

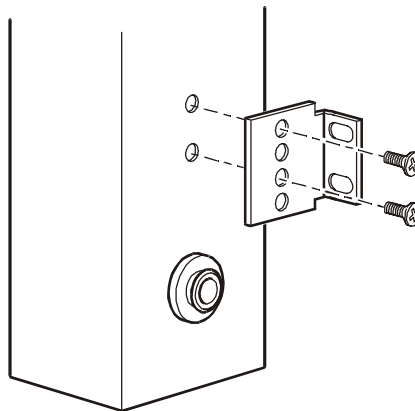
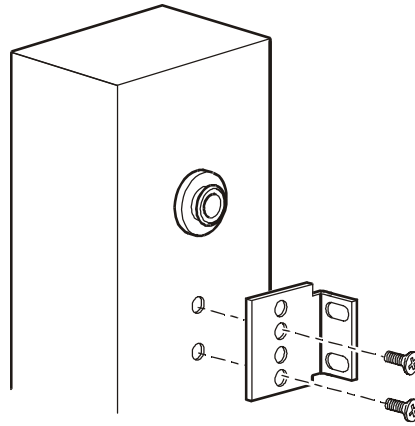

2. Install the Rack PDU on a vertical mounting rail in your rack or enclosure.

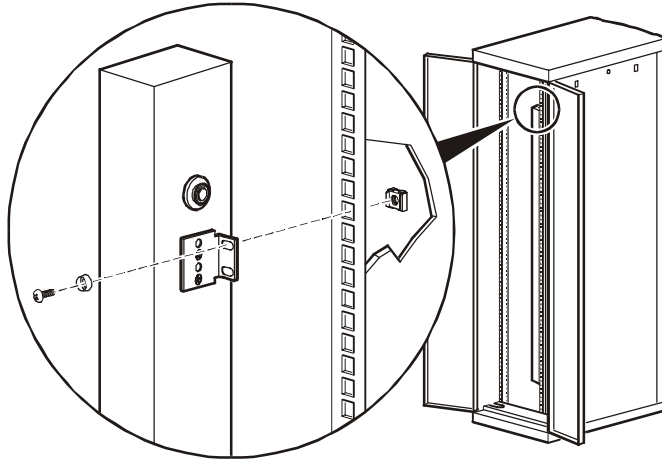

Specifications

AP7551

Electrical

Nominal input voltage	230 V
Acceptable input voltage	± 10% Nominal input voltage
Input frequency	47–63 Hz
Cord length	3 ft
Input connectors	IEC 309 plug
Output connectors	Twenty IEC 320 C13; Four IEC 320 C19 outlets
Maximum total current draw	16 A

Physical

Size (H × W × D)	63.75 × 2.19 × 1.73 in (161.92 × 5.56 × 4.39 cm)
Weight	9.5 lb (4.3 kg)
Shipping weight	17 lb (7.7 kg)

Environmental

Elevation (above MSL)	
Operating	0–15 000 ft (0–4500 m)
Storage	0–50 000 ft (0–15 000 m)
Temperature	
Operating	–5 to 45° C (23 to 115° F)
Storage	–25 to 65° C (–13 to 149° F)
Humidity	
Operating	5–95% RH, Non-condensing
Storage	5–95% RH, Non-condensing

Compliance

Safety verification	VDE 0805, CE, EN 60950, IEC 60950
---------------------	-----------------------------------

Warranty and Service

Limited warranty

APC warrants the Rack PDU to be free from defects in materials and workmanship for a period of two years from the date of purchase. Its obligation under this warranty is limited to repairing or replacing, at its own sole option, any such defective products. This warranty does not apply to equipment that has been damaged by accident, negligence, or misapplication or has been altered or modified in any way. This warranty applies only to the original purchaser.

Warranty limitations

Except as provided herein, APC makes no warranties, express or implied, including warranties of merchantability and fitness for a particular purpose. Some jurisdictions do not permit limitation or exclusion of implied warranties; therefore, the aforesaid limitation(s) or exclusion(s) may not apply to the purchaser.

Except as provided above, in no event will APC be liable for direct, indirect, special, incidental, or consequential damages arising out of the use of this product, even if advised of the possibility of such damage.

Specifically, APC is not liable for any costs, such as lost profits or revenue, loss of equipment, loss of use of equipment, loss of software, loss of data, costs of substitutes, claims by third parties, or otherwise. This warranty gives you specific legal rights and you may also have other rights, which vary according to jurisdiction.

Obtaining service

To obtain support for problems with your Rack PDU:

1. Note the serial number and date of purchase. The serial number is located on the bottom of the PDU.
2. Contact Customer Support at a phone number located on the back cover. A technician will try to help you solve the problem by phone.
3. If you must return the product, the technician will give you a return material authorization (RMA) number. If the warranty expired, you will be charged for repair or replacement.
4. Pack the unit carefully. The warranty does not cover damage sustained in transit. Enclose a letter with your name, address, RMA number and daytime phone number; a copy of the sales receipt; and a check as payment, if applicable.
5. Mark the RMA number clearly on the outside of the shipping carton.
6. Ship by insured, prepaid carrier to the address provided by the Customer Support technician.

Life-Support Policy

General policy

American Power Conversion (APC) does not recommend the use of any of its products in the following situations:

- In life-support applications where failure or malfunction of the APC product can be reasonably expected to cause failure of the life-support device or to affect significantly its safety or effectiveness.
- In direct patient care.

APC will not knowingly sell its products for use in such applications unless it receives in writing assurances satisfactory to APC that (a) the risks of injury or damage have been minimized, (b) the customer assumes all such risks, and (c) the liability of American Power Conversion is adequately protected under the circumstances.

Examples of life-support devices

The term *life-support device* includes but is not limited to neonatal oxygen analyzers, nerve stimulators (whether used for anesthesia, pain relief, or other purposes), autotransfusion devices, blood pumps, defibrillators, arrhythmia detectors and alarms, pacemakers, hemodialysis systems, peritoneal dialysis systems, neonatal ventilator incubators, ventilators (for adults and infants), anesthesia ventilators, infusion pumps, and any other devices designated as “critical” by the U.S. FDA.

Hospital-grade wiring devices and leakage current protection may be ordered as options on many APC UPS systems. APC does not claim that units with these modifications are certified or listed as hospital-grade by APC or any other organization. Therefore these units do not meet the requirements for use in direct patient care.



APC Worldwide Customer Support

Customer support for this or any other APC product is available at no charge in any of the following ways:

- Visit the APC Web site to access documents in the APC Knowledge Base and to submit customer support requests.
 - **www.apc.com** (Corporate Headquarters)
Connect to localized APC Web sites for specific countries, each of which provides customer support information.
 - **www.apc.com/support/**
Global support searching APC Knowledge Base and using e-support.
- Contact an APC Customer Support center by telephone or e-mail.
 - Regional centers:

Direct InfraStruXure Customer Support Line	(1)(877)537-0607 (toll free)
APC headquarters U.S., Canada	(1)(800)800-4272 (toll free)
Latin America	(1)(401)789-5735 (USA)
Europe, Middle East, Africa	(353)(91)702000 (Ireland)
Japan	(0) 3 5434-2021
Australia, New Zealand, South Pacific area	(61) (2) 9955 9366 (Australia)

- Local, country-specific centers: go to **www.apc.com/support/contact** for contact information.

Contact the APC representative or other distributor from whom you purchased your APC product for information on how to obtain local customer support.

Entire contents copyright © 2004 American Power Conversion. All rights reserved.

Reproduction in whole or in part without permission is prohibited. APC, the APC logo, InfraStruXure, and NetShelter are trademarks of American Power Conversion Corporation and may be registered in some jurisdictions. All other trademarks, product names, and corporate names are the property of their respective owners and are used for informational purposes only.



990-1419A-001



03/2004