

## CABLE MANAGEMENT SYSTEM FOR FREE-STANDING RACKS

### HOLDERS OF VERTICAL WIRE MANAGEMENT PANELS AND CABLE BRACKETS

**Description:**

Used for installation of vertical wire management panels and cable brackets (ordered separately) in racks ROF, RSL, REV, and RMF series width 800mm

- For REV series special connecting kit HVM-H-REV needed
- For RSL series special connecting kit HVM-H-RSL needed
- Set includes 2 holders
- Mounting kit included
- Color powder coated RAL (standard RAL 9005)

Code	Rack height (U)			
	ROF	RSL	REV	RMF
HVM-15	15	-	18	-
HVM-18	18	-	21	-
HVM-21	21	21	24	21
HVM-24	-	-	27	-
HVM-27	27	27	-	-
HVM-30	-	-	33	-
HVM-33	33	-	36	33
HVM-36	36	-	-	-
HVM-39	-	-	42	-
HVM-42	42	42	45	42
HVM-45	45	45	-	45
HVM-48	48	-	-	-

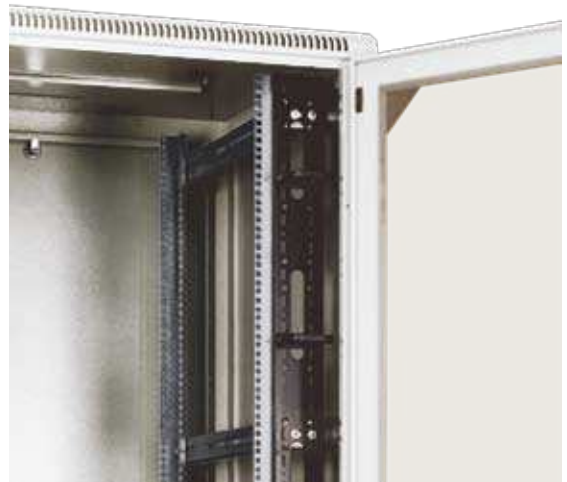

HVM with installed VO-80/80 brackets

### CONNECTING KIT FOR HOLDERS OF VERTICAL WIRE MANAGEMENT PANELS FOR RSL AND REV SERIES

**Description:**

- Set of 4 fittings
- Set used for mounting of 2 holders of vertical wire management panels
- Mounting kit included
- Code: HVM-H-REV for REV series
- Code: HVM-H-RSL for RSL series

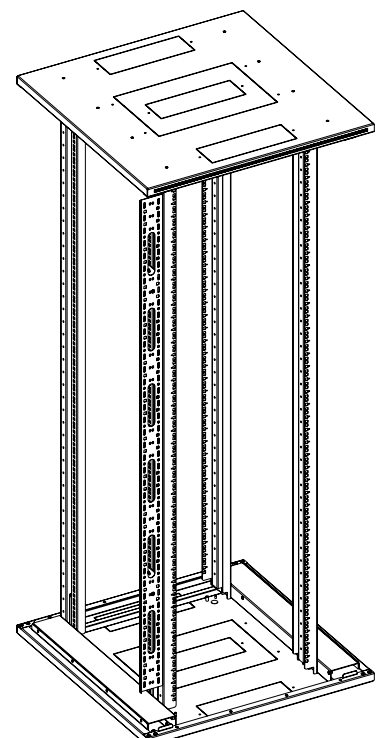
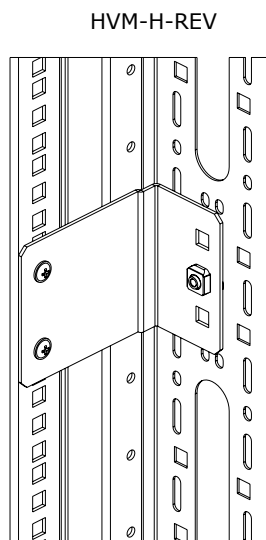
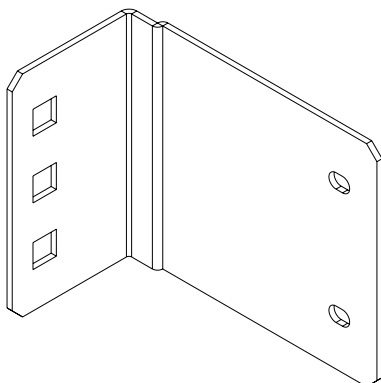

## VERTICAL WIRE MANAGEMENT PANELS - PLASTIC

Used for storing and managing cables vertically in 800mm wide free-standing racks ROF, RSL, REV, RMF, and RHF.

### Description:

- Produced for rack sizes 15-48U
- Plastic duct size 80x60mm for cable management
- Ducts of 33U and over have divided cover for easier handling
- Installed on front part of vertical extrusions by using holders of vertical wire management panels (see HVM - page 68) - ordered separately
- Oval openings in base of ducts and in vertical extrusions allow front to rear cabling
- Color black



Code	Rack height (U)				
	ROF	RSL	REV	RMF	RHF
	80/60, 80/80, 80/100, 80/110, 80/120	80/60, 80/80	80/80	80/80, 80/100	80/100
DP-VP-VR-15	15	-	18	-	-
DP-VP-VR-18	18	-	21	-	-
DP-VP-VR-21	21	21	24	21	-
DP-VP-VR-24	-	-	27	-	-
DP-VP-VR-27	27	27	-	-	-
DP-VP-VR-30	-	-	33	-	-
DP-VP-VR-33	33	-	36	33	-
DP-VP-VR-36	36	-	-	-	-
DP-VP-VR-39	-	-	42	-	-
DP-VP-VR-42	42	42	45	42	42
DP-VP-VR-45	45, 48	45	-	45	-

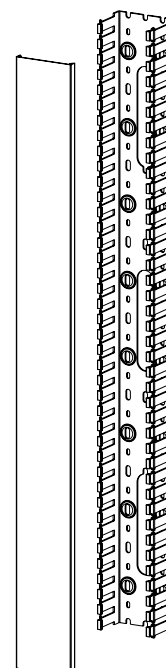

## CABLE BASKET TRAYS FOR FREE-STANDING RACKS ROF, RSL, REV, AND RMF SERIES

### Description:

- Used to guide and support vertical cables in free-standing racks between 19" extrusions and side panels
- Two types:
  - a) width x depth: 140x30mm; in racks RSL and REV series width 600mm mounted on inner side of horizontal holder
  - b) width x depth: 140x60mm; only suitable for racks width 800mm
- Produced for rack sizes 15-48U
- Mounted on holders of vertical extrusions in ROF and RMF series, horizontal holders are needed for racks of 18, 21, and 27U; in RSL and REV series horizontal holders are needed for all sizes of racks
- Set of fittings included

Code	Dimensions in mm			Used in rack height (U)
	H	W	D	
HVMS-B-600-140/30	605	170	35	15,18
HVMS-B-800-140/30	805	170	35	21
HVMS-B-1000-140/30	1005	170	35	24, 27
HVMS-B-1400-140/30	1405	170	35	33, 36
HVMS-B-1800-140/30	1805	170	35	42, 45, 48
HVMS-B-600-140/60	605	170	65	15, 18
HVMS-B-800-140/60	805	170	65	21
HVMS-B-1000-140/60	1005	170	65	24, 27
HVMS-B-1400-140/60	1405	170	65	33, 36
HVMS-B-1800-140/60	1805	170	65	42, 45, 48



## HORIZONTAL HOLDERS FOR SIDE CABLE MANAGEMENT

### Description:

- Used for fitting vertical cable trays in racks ROF and RMF series of 18, 21, and 27U; always needed in RSL and REV racks
- Also used as cable holders
- Two types:
  - a) for racks ROF and RMF series only - HVMS-H-M-xx/yy (mounted to rack frame)
  - b) for free standing racks - HVMS-H-yyyy (mounted on vertical extrusions)
- Possibility to install plastic cable brackets
- Set includes 2 holders
- Mounting kit included

Code	Used in rack sizes		
	ROF, RMF	RSL	REV
HVMS-H-M-60/60	600x600	-	-
HVMS-H-M-60/80	600x800	-	-
HVMS-H-M-60/100	600x1000	-	-
HVMS-H-M-80/60	800x600	-	-
HVMS-H-M-80/80	800x800	-	-
HVMS-H-M-80/100	800x1000	-	-
HVMS-H-600	600x600 800x600	600x600 800x600	600x600
HVMS-H-800	600x800 800x800	600x800 800x800	600x800 800x800

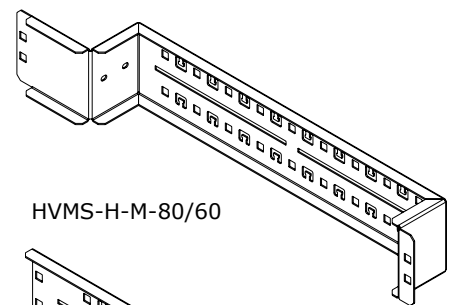

HVMS-H-M-80/60

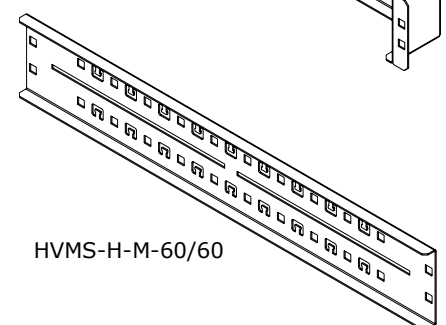

HVMS-H-M-60/60

## HORIZONTAL SIDE CABLE HOLDERS

### Description:

- Used for side cable management in rack
- Produced for rack of depth 600, 800, and 1000mm
- Set of fittings included

Rack size in mm W x D	Rack series			
	ROF	RSL	REV	RMF
600x600	HVMS-CH-500	HVMS-CH-500	HVMS-CH-400	HVMS-CH-500
600x800	HVMS-CH-700	HVMS-CH-700	HVMS-CH-600	HVMS-CH-700
600x1000	HVMS-CH-800			
800x600	HVMS-CH-400	HVMS-CH-500		
800x800	HVMS-CH-600	HVMS-CH-700	HVMS-CH-600	HVMS-CH-600
800x1000	HVMS-CH-800			HVMS-CH-800



## PANELS FOR SIDE VERTICAL CABLE MANAGEMENT

### Description:

- Used to guide and support vertical cables in free-standing racks between 19" extrusions and side panels
- Produced in two widths – 150mm and 300mm
- Produced for racks sizes 15 – 48U
- Set of fittings included

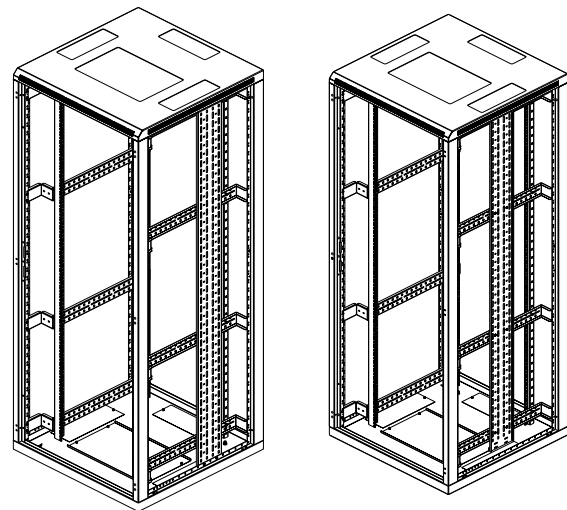

Code		Rack height in U				
panels width 150mm	panels width 300mm	ROF*	RMF**	ROS*	REV***	RSL****
DP-VV-15U/150	DP-VV-15U/300	15		15		
DP-VV-18U/150	DP-VV-18U/300	18		18	21	
DP-VV-21U/150	DP-VV-21U/300	21	21	21	24	21
DP-VV-24U/150	DP-VV-24U/300	24		24	27	
DP-VV-27U/150	DP-VV-27U/300	27		27	33	27
DP-VV-30U/150	DP-VV-30U/300	30		30		
DP-VV-33U/150	DP-VV-33U/300	33	33	33		
DP-VV-36U/150	DP-VV-36U/300	36		36	42	
DP-VV-42U/150	DP-VV-42U/300	42	42	42	45	42
DP-VV-45U/150	DP-VV-45U/300	45	45	45		45
DP-VV-48U/150	DP-VV-48U/300	48		48		

\* Installation either directly in top and bottom frame of the rack or on holders of vertical extrusions

\*\* Installation on holders of vertical extrusions only

\*\*\* Installation on horizontal holders for side cable management HVMS-H-yyy only (to be ordered separately)

\*\*\*\* Installation either in top and bottom frame of the rack or on holders of vertical extrusions for side cable management HVMS-H-yyy (to be ordered separately)