

THIS COPY IS PROVIDED ON A RESTRICTED BASIS AND IS NOT TO BE USED IN ANY WAY DETRIMENTAL TO THE INTERESTS OF PANDUIT CORP.

PANDUIT P/N	WEIGHT
CFPFS2**	.23 LB/10 PCS (106.3g/10 PCS)

- NOTES:
- SEE CURRENT CATALOG FOR ADDITIONAL PART NUMBER SUFFIXES TO INDICATE COLOR AND OR PACKAGE QUANTITY.
 - SEE CATALOG FOR COMPLETE LIST OF PARTS APPLICABLE FOR USE WITH THIS PART.
 - DIMENSIONS IN PARENTHESES ARE IN METRIC.
 - PART INCLUDES:
1 - 45 X 45 ADAPTER
1 - 2 POSITION SLOPED INSERT

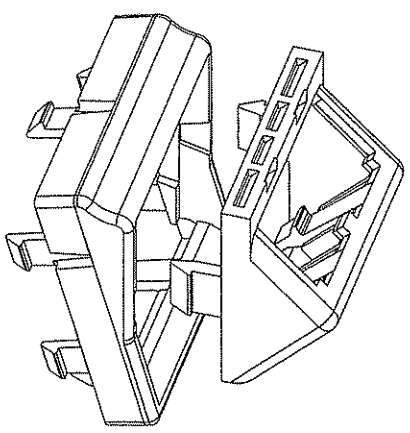
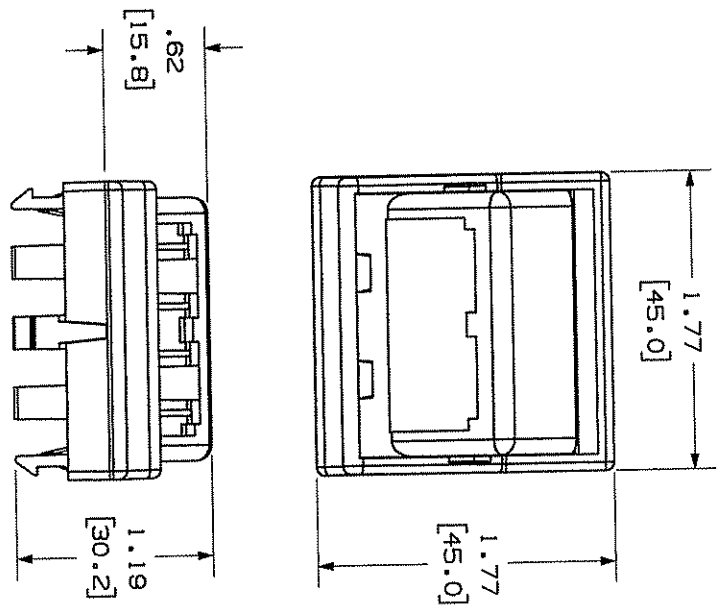

CAD FILENAME/LAYERS
M00142CS_DC_00B.PRT

PANDUIT

CORP., TINLEY PARK, ILLINOIS

45 X 45 FRENCH ADAPTER KIT

(CFPFS2**) CUSTOMER DRAWING

UNLESS OTHERWISE SPECIFIED, DIMENSIONAL TOLERANCES ARE:
(.XX) ±.03(.8) ANGLES ±

UNLESS OTHERWISE SPECIFIED, ALL DIMENSIONS ARE GIVEN IN INCHES, THIRD ANGLE PROJECTION.

DATE	1-10-00	DRAWN BY	JSP	MAT'L:	SCALE	NONE	DWG	00142-45	A
CHECKED BY	PBD								

REV	DATE	BY	CHK	DESCRIPTION	ECN	CHK	CUST	SUP
1	2-21-00	JSP	PBD	A. INCORRECT P/N.	00142-45	PBD	PBD	
R	1-10-00	JSP	PBD	RELEASED TO PRODUCTION.	00142-45	PBD		