

P&T ADAPTERS

REVISION 0945



MAIN FEATURES

Robust construction

Epoxy powder painted

DESCRIPTION

WSFPA

Die-cast aluminium reinforced support plate, suitable for PTAC bracket. Epoxypolyester powder painted.

PTCC1

Pole mount adapter for PTBC bracket. It firmly fixes the PTH900 Pan & Tilt and its bracket to the pole. Epoxypolyester powder painted.

WCWA

Corner adapter for PTAC bracket. Constructed from steel and epoxypolyester powder painted.

WCWGC

Corner adapter for PTBC bracket. It allows the Pan & Tilt/bracket couple to be firmly attached to the corner. Constructed from steel, the adapter is epoxypolyester powder painted.

WCPA

Die-cast aluminium reinforcing support plate, suitable PTAC bracket. The cable can pass internally through a slot and connect to the WBOVA2 bracket. Epoxypolyester powder painted.

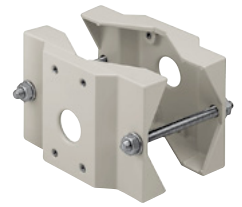

WSFPA



PTCC1

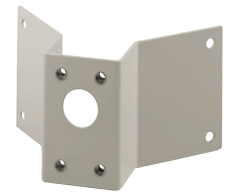

WCWA

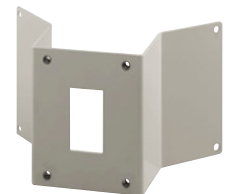

WCWGC



WCPA

P&T ADAPTERS

AVAILABLE MODELS		
	Brackets for P&T's	
	PTBC	PTAC
Pole mount adaptor		
WSFPA		•
PTCC1	•	
Corner adaptor		
WCWA		•
WCWGC	•	
Support plate adaptor		
WCPA		•

TECHNICAL DATA

GENERAL

Constructed from aluminium (WSFPA, PTCC1, WCPA)
 Constructed from steel (WCWA, WCWGC)
 Epoxypolyester powder painting, RAL9002 colour
 Stainless steel screws

MECHANICAL

WSFPA

Pole installation
 Load rating: 30kg (66lb)
 Pole: Ø 65 - 110mm (2.5 - 4.3in)

PTCC1

Pole installation
 Load rating: 50kg (110lb)
 Pole: Ø 80 - 150mm (3.14 - 5.9in)

WCWA

Corner installation
 Load rating: 30kg (66lb)

WCWGC

Corner installation
 Load rating: 50kg (110.2lb)

WCPA

Wall installation
 Load rating: 50kg (110lb)

ENVIRONMENT

Indoor / Outdoor

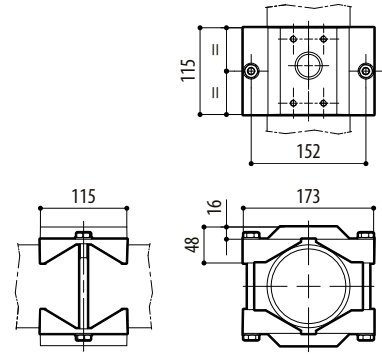

WSFPA

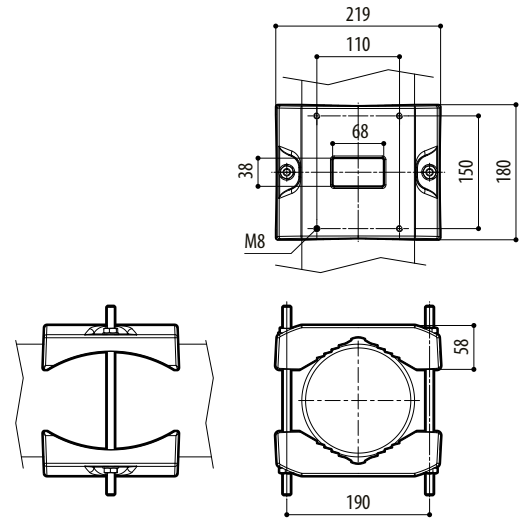

PTCC1

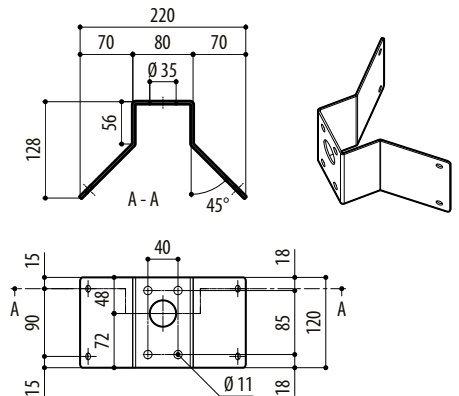

WCWA

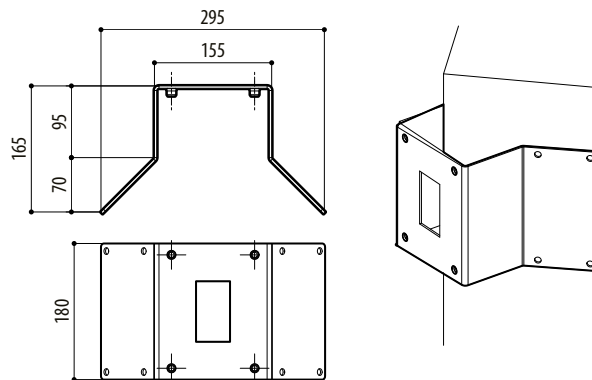

WCWGC

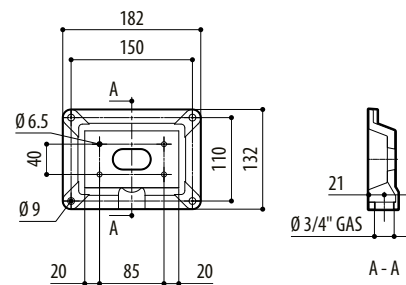

WCPA

mm 1:10

PACKAGE							
Code	Unit weight		Package weight		Package dimensions (WxHxL)		Master carton unit
	kg	lb	kg	lb	cm	in	
WSFPA	0.9	2.0	1.0	2.2	10.0x16.0x23.0	3.9x6.3x9.0	30
PTCC1	2.6	5.7	2.8	6.2	14.0x25.5x20.0	5.5x10.0x7.9	10
WCWA	1.0	2.2	1.1	2.4	14.5x15.0x27.0	5.7x5.9x10.6	15
WCWGC	2.2	4.9	2.6	5.7	24.0x32.0x24.5	9.5x12.6x9.6	6
WCPA	0.6	1.3	0.7	1.5	10.0x16.0x23.0	3.9x6.3x9.1	30

P&T ADAPTERS