



19" BLANK AND FAST BLANK PANELS

Used to cover empty positions in rack to minimize by-pass airflow and enhance aesthetic appearance.

DESCRIPTION:

- Height 1, 2, 3, and 5U
- Color powder coated RAL (standard RAL 9005)
- Tool-less solution uses quarter turn fasteners

For tool-less design use code with the suffix F.

Code	Height	Width
DP-ZA-1U	1U	19"
DP-ZA-2U	2U	19"
DP-ZA-3U	3U	19"
DP-ZA-5U	5U	19"
DP-ZA-1F	1U	19"
DP-ZA-2F	2U	19"
DP-ZA-3F	3U	19"
DP-ZA-5F	5U	19"

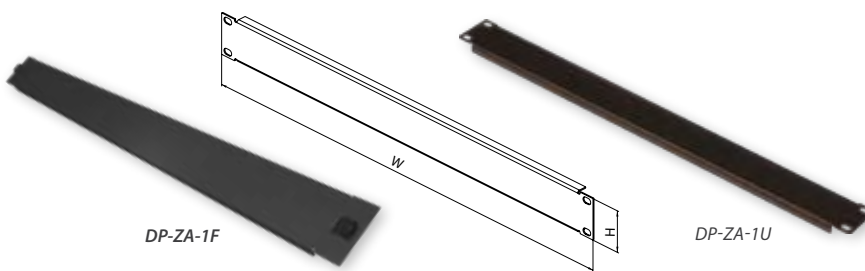

ILLUSTRATIVE IMAGE OF THE AIRFLOW IN A RACK

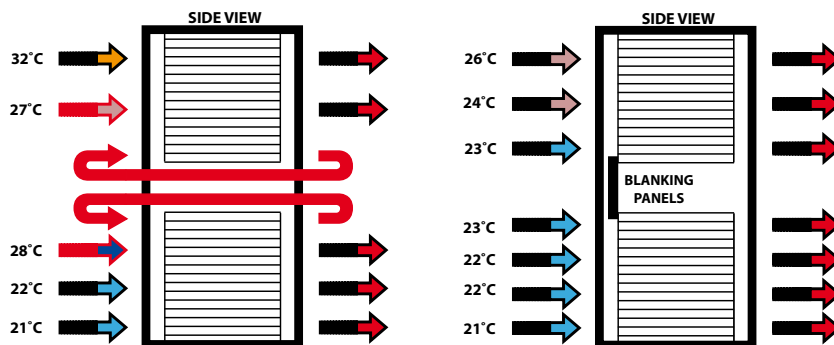

19" VENTED PANEL

Enables front to rear cable passage through empty positions in rack.

DESCRIPTION:

- Height 1U
- Width 19"
- Color powder coated RAL (standard RAL 9005)

Code	Height	Width
DP-01-VENT	1U	19"

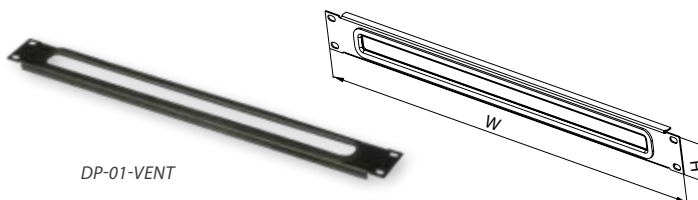

19" VENTED PANEL WITH BRUSH

Enables front to rear cable passage through empty positions in rack whilst helping to minimize by-pass airflow.

DESCRIPTION:

- Types:
 - a) with brush
 - b) with brush and cable management
- Vented panel with brush and cable management has cable management bar on back and two cable brackets 40x50mm on sides
- Height 1U
- Color powder coated RAL (standard RAL 9005)

Code	Height	Width	Depth in mm
DP-BP-02	1U	19"	85
DP-BP-03	1U	19"	--

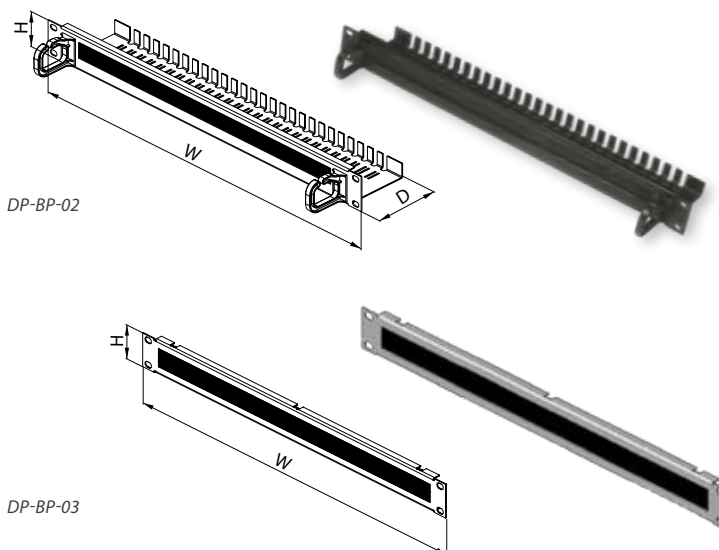

19" blank panels / 19" vented panels