

19" SHELVES

Used for storing equipment, which is not mounted on 19" vertical extrusions.

Description:

- Whole surface perforated for effective ventilation
- Color powder coated RAL (standard RAL 9005)
- Types:
 - a) fixed lite, code DP-PT
 - b) fixed, code DP-PO
 - c) pull-out, code DP-PO-V
 - d) pull-out, high load, code DP-PZ-V
 - e) keyboard holders, code DP-PV
 - f) fixed high load, code DP-PZ
- Pull-out drawer DP-DD suitable for document storage

19" FIXED LITE SHELVES SERIES DP-PT

Description:

- Made of 1.5mm sheet steel
- Supporting brackets included
- Load rating max. 20kg balanced load; maximum load rating decreased to 25% when mounted only on front pair of vertical extrusions (shelves depth 150, 250, and 350mm)
- Longer supporting bracket DP-PO-PD can be used

See page 55 – Supporting brackets

SHELVES SERIES DP-PT			
Code	W	D in mm	H
DP-PT-150	19"	150	1U
DP-PT-250	19"	250	1U
DP-PT-350	19"	350	1U
DP-PT-450	19"	450	1U
DP-PT-550	19"	550	1U
DP-PT-650	19"	650	1U
DP-PT-750*	19"	750	1U
DP-PT-850*	19"	850	1U

* Using of supporting brackets recommended

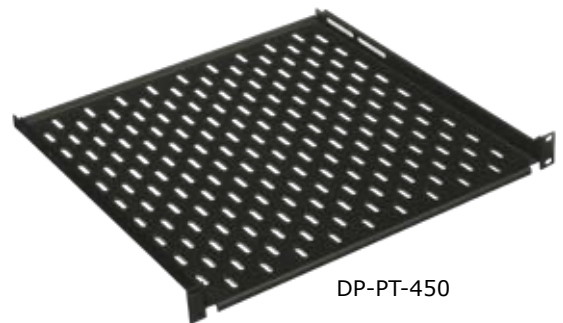

DP-PT-450

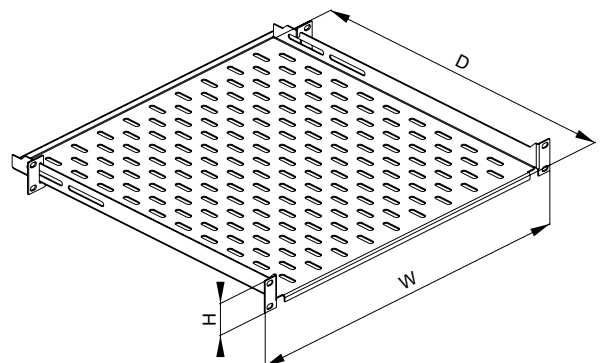

19" PULL-OUT SHELVES SERIES DP-PO-V

Description:

- Made of 1.5mm sheet steel
- Height 1U
- Equipped with one pair of side telescopic rails
- Supporting brackets included
- Load rating max. 25kg balanced load; maximum load rating decreased to 25% when mounted only on front pair of vertical extrusions (shelves depth 250 and 350mm)

SHELVES SERIES DP-PO-V			
Code	W	D in mm	H
DP-PO-250V	19"	250	1U
DP-PO-350V	19"	350	1U
DP-PO-450V	19"	450	1U
DP-PO-550V	19"	550	1U
DP-PO-650V	19"	650	1U
DP-PO-750V	19"	750	1U

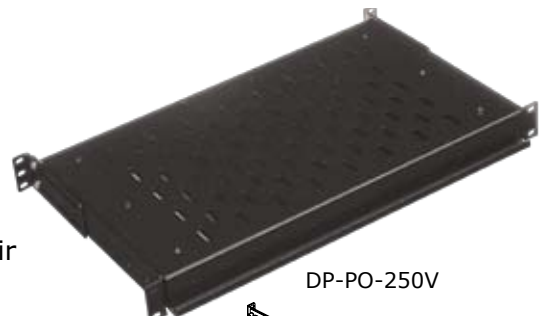

DP-PO-250V

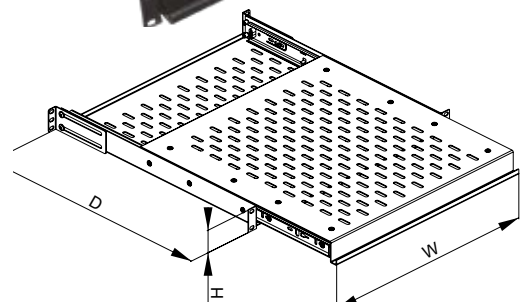

19" PULL-OUT HIGH LOAD SHELVES SERIES DP-PZ-V

Accessories

Description:

- Made of 2mm, 2.5mm sheet steel
- Height 1U
- Max. pull-out 450mm
- Load rating max. 80kg balanced load

DP-PZ-450V

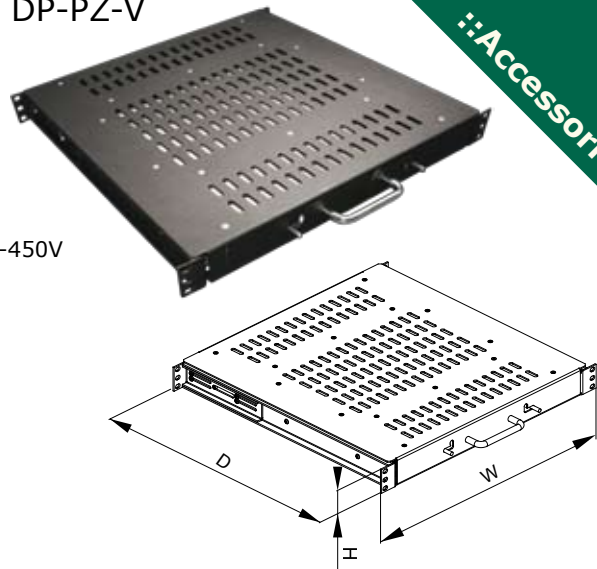

SHELVES SERIES DP-PZ-V			
Code	H in U	W	D in mm
DP-PZ-450V	1	19"	505
DP-PZ-550V	1	19"	605

19" FIXED SHELVES SERIES DP-PO

Description:

- Made of 2mm sheet steel
- Possibility of adding supporting brackets
- Load rating max. 15kg balanced load (when mounted only on front pair of vertical extrusions - shelves depth 150, 250, and 350mm); can be increased up to 60kg when supporting brackets applied (ordered separately)

DP-PO-450

SHELVES SERIES DP-PO			
Code	W	D in mm	H
DP-PO-150	19"	150	1U
DP-PO-250	19"	250	1U
DP-PO-350	19"	350	2U
DP-PO-450	19"	450	2U
DP-PO-550	19"	550	2U
DP-PO-650	19"	650	2U
DP-PO-750	19"	750	2U
DP-PO-850	19"	850	2U

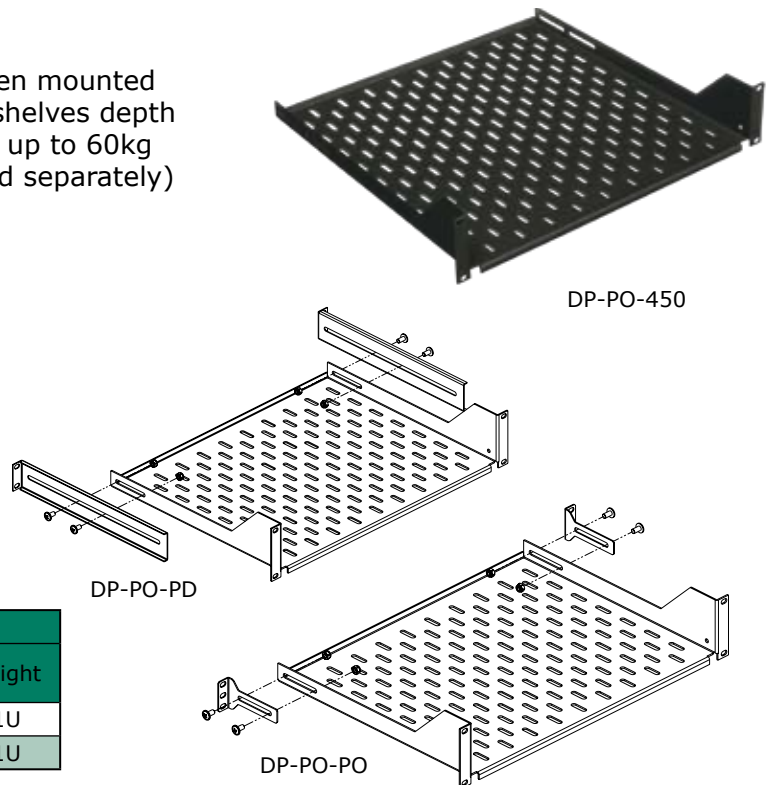

SUPPORTING BRACKETS				
Code	Type	Packing	Length in mm	Height
DP-PO-PO	Standard	1 PAIR	88	1U
DP-PO-PD	Extended	1 PAIR	298	1U

19" PULL-OUT DRAWER DP-DD

Description:

- Made of 1.25 and 1.5mm sheet steel
- Height 3U
- Max. pull-out distance 280mm
- Load rating max. 10kg balanced load

19" PULL-OUT DRAWER			
Code	H in U	W	D in mm
DP-DD-03	3	19"	430

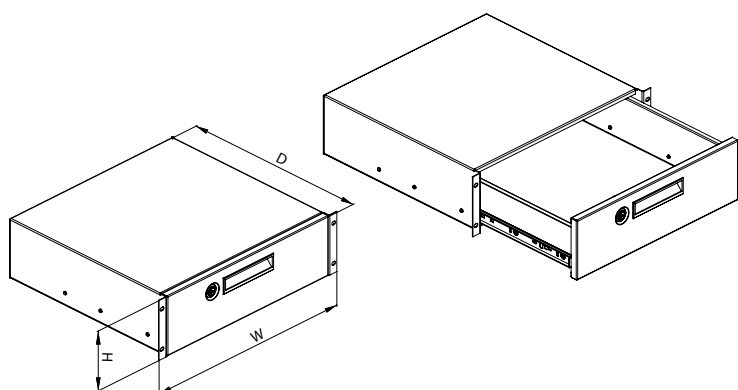

19" FOLDING KEYBOARD HOLDER SERIES DP-PV

Description:

- Enables keyboard placement in front of sliding vertical extrusions
- Max. keyboard size 480x175mm
- Height 1U
- Fix keyboard to shelf using self-adhesive velcro - 8 pcs of size 12 x 25mm included

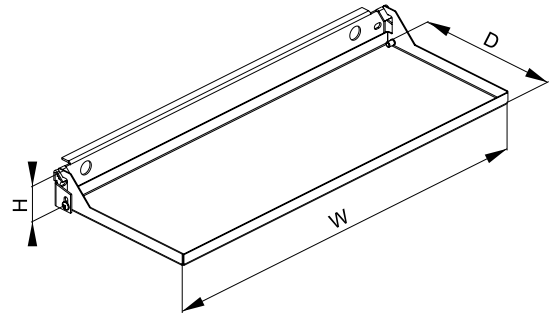

19" FOLDING HOLDER FOR KEYBOARD		
Code	W	H
DP-PV-01	19"	1U



19" PULL-OUT KEYBOARD HOLDER SERIES DP-PV

Description:

- Made of 1.5mm sheet steel
- Max. keyboard width 400mm and height 36mm
- Depth of shelf 480mm
- Max. pull-out distance 330mm
- Supporting brackets included

19" PULL-OUT HOLDER FOR KEYBOARD			
Code	W	D in mm	H
DP-PV-02	19"	480	1U

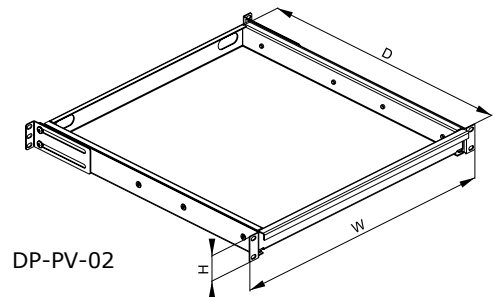

- Supporting brackets DP-PV-PD for installation into racks depth 800 and 1000mm available optionally

19" FIXED HIGH-LOAD SHELVES SERIES DP-PZ

Description:

- Made of 2mm sheet steel, strengthened by two metal bars
- Four supporting brackets for mounting on vertical extrusions included
- Load rating max. 100kg balanced load

19" SHELVES SERIES DP-PZ			
Code	W	D in mm	H
DP-PZ-450	19"	450	1U
DP-PZ-550	19"	550	1U
DP-PZ-650	19"	650	1U
DP-PZ-750	19"	750	1U
DP-PZ-850	19"	850	1U

