

**NOTE**



All numerical values are in metric units [with U.S. customary units in brackets]. Dimensions are in millimeters [and inches]. Unless otherwise specified, dimensions have a tolerance of  $\pm 0.13$  [ $\pm .005$ ] and angles have a tolerance of  $\pm 2^\circ$ . Figures and illustrations are for identification only and are not drawn to scale.

**1. INTRODUCTION**

This specification covers the requirements for application of the Undercarpet Power System and is intended as an aid to architects, consulting engineers, building contractors, and electricians.

The Undercarpet Power System is a branch circuit wiring method per Article 324 of the 2002 National Electric Code. The wiring system includes, but is not necessarily restricted to, the components listed and shown in Figure 1. The following list provides a brief description of the system components. Use these terms when corresponding with Tyco Electronics Representatives to facilitate assistance.

*Transition Fitting:* Box-type configuration which houses and protects the transition block assembly.

*Transition Block Assembly:* Terminating component designed to make the transition from round conductors to flat conductors.

*Direct Connecting Receptacle:* A low-profile duplex receptacle terminated directly to the flat cable.

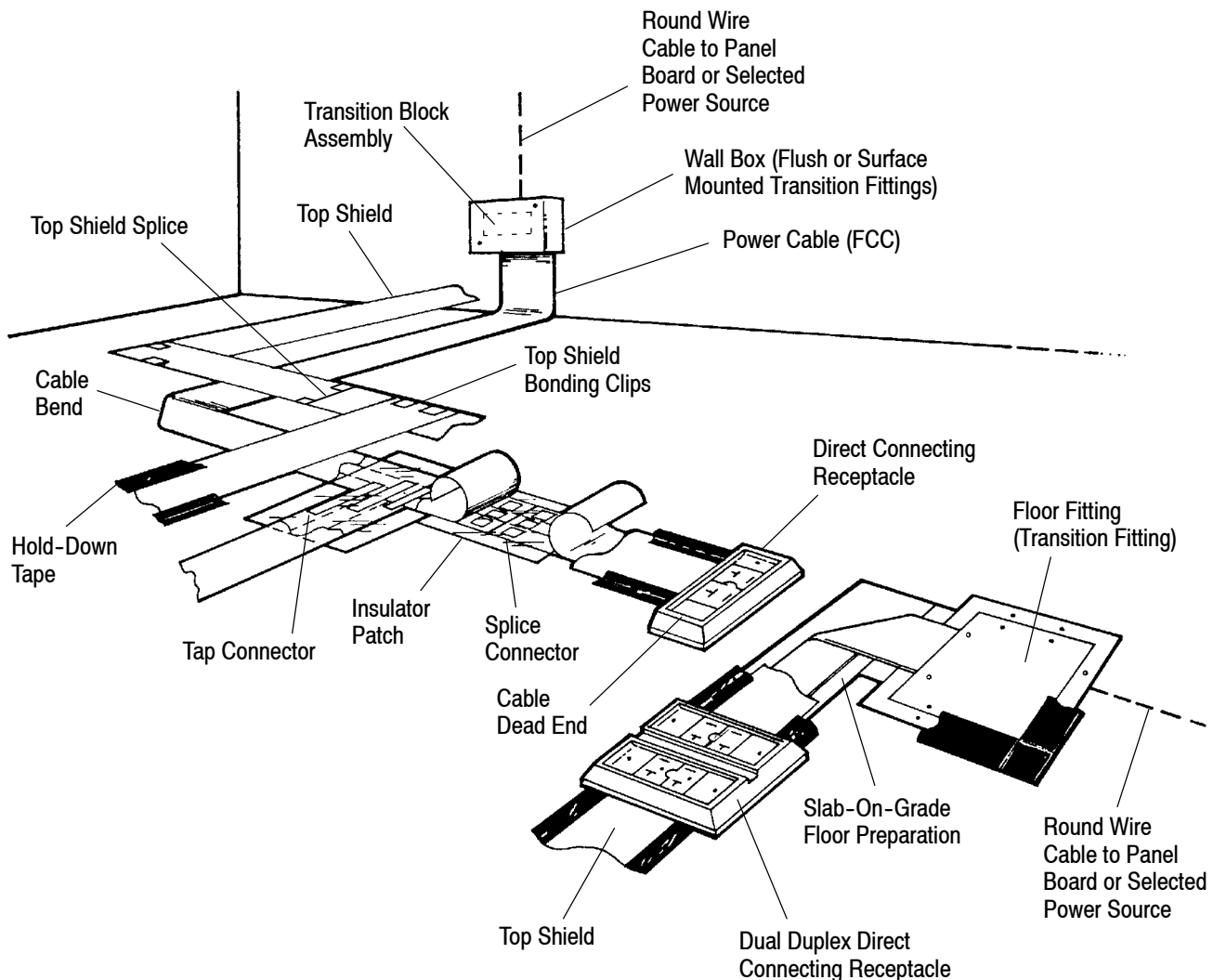

Figure 1

---

*Floor Preparation:* A polyvinyl sheet 0.25 mm [.010 in.] thick, designed to protect the cable from floor moisture, chemical reaction, and abrasion in slab-on-grade level applications.

*Flat Conductor Cable (FFC):* Flat copper conductors between non-conductive laminated polyvinylchloride (pvc) with polyester film outer layer.

*Top Shield:* Steel sheet 0.25 mm [.010 in.] thick, placed over flat conductor cable to provide physical protection and an additional electrical ground path.

*Tap Connector:* Terminating device designed to electrically connect two flat conductor cables perpendicular to each other.

*Splice Connector:* Terminating device designed to electrically connect two flat conductor cables to extend the cable length.

*Top Shield Bonding Clip:* Connector used to splice and tap the top shield.

*Insulator Patch:* Used to insulate tap and splice connectors and protect exposed conductor ends or areas.

When corresponding with Tyco Electronics Personnel about this product, use the terminology provided in this specification to facilitate your inquiries for information. Basic terms and features of this product are provided in Figure 1.

## 2. REFERENCE MATERIAL

### 2.1. Revision Summary

This paragraph is reserved for a revision summary covering the most recent additions and changes made to this specification which include the following:

- Updated document to corporate requirements
- New logo and format

### 2.2. Customer Assistance

Reference Base Part Number 553239 and Product Code 1260 are representative numbers of Undercarpet Power System. Use of these numbers will identify the product line and expedite your inquiries through a service network established to help you obtain product and tooling information. Such information can be obtained through a local Tyco Electronics Representative or, after purchase, by calling the Tooling Assistance Center or the Product Information number at the bottom of page 1.

### 2.3. Drawings

Customer Drawings for specific products are available from the responsible Tyco Electronics Engineering Department via the service network. The information contained in Customer Drawings takes priority if there is a conflict with this document or with any other technical documentation supplied by Tyco Electronics.

### 2.4. Specifications/Standards

Various Product Specifications are available to cover test and performance requirements of the undercarpet components.

Flat conductor cable is restricted to use under carpet squares in commercial facilities and must conform to the following standards, codes, and listings:

- National Electrical Code
- National Fire Protection Association (NFPA) 70E.
- Underwriters Laboratories Inc. (UL)
- CSA International

### 2.5. Instructional Material

Tyco Electronics Instruction Sheets are available to cover installation and assembly of individual components. The instruction sheets are packaged with the components.

Undercarpet Cabling Systems (Layout and Planning Manual) 409-5566 includes floor preparation procedures, precautions and suggestions for proper layout techniques, considerations for economizing in material and labor requirements, physical and functional descriptions of all components in each system, techniques for preparing material take-off lists, and encapsulated installation instructions.

### 3. REQUIREMENTS

#### 3.1. General

Use all necessary care to avoid damaging the components of the Undercarpet Power System before, during, and after installation and to protect the installed work and materials from all other trades.

Prior to all work involving the Undercarpet Power System, verify that the work of all other trades is complete to the point where this installation may properly commence.

The time for Undercarpet Power System installation is just prior to carpet installation.

1. In the event that the work of other trades is not complete, report the discrepancies to the engineer in charge.
2. Do not proceed with installation in areas of discrepancy until all discrepancies have been fully resolved.

#### 3.2. Installation

##### A. Drawing

Before the Undercarpet Power System is actually installed, a system layout drawing (containing all elements of the circuit) should be made.

##### B. Mounting the Transition Fitting/Transition Block Assembly

Referring to the system layout drawing, mount the transition fitting and transition block assembly at the specified location, using fasteners appropriate for the type of fitting and the site construction encountered. Mounting details are provided on the instruction sheet packaged with the fitting.

##### C. Preparing the Floor

- Uneven floors with irregularities must be leveled or patched.
- Concrete slabs must have all holes filled and projections removed to ensure a smooth surface.
- Porous floors must be sealed and free from grease, oil, and moisture.
- Clean floor thoroughly. Sweep and vacuum to remove all debris. Maintain clean area throughout installation.
- Do not install Undercarpet System on or in wet areas where water or liquids will be evident.

**NOTE**

*Tyco Electronics does not warrant proper functions of installations that are not installed in accordance with preceding procedures.*

##### D. Marking the Floor

Lay out the details of the branch circuit wiring on the floor using chalk lines and the appropriate symbols to indicate the cable run, transition block assembly locations, and tap points.

**NOTE**

*It is recommended that necessary floor fitting anchor holes be drilled at this time so the floor may be cleared of debris before laying the bottom shield.*

##### E. Laying the Floor Preparation

It is important that the bottom shield be installed on a clean, dry floor.

1. Starting at the transition fitting, lay the floor preparation over the floor marking. Exercise caution to keep the floor preparation straight and smooth.
2. Cut the floor preparation as necessary with scissors.
3. Edge-tape the floor preparation to the floor periodically to hold it in place.
4. Follow the instructions packaged with the floor preparation for installation specifics and recommendations.

#### F. Installing the Flat Conductor Cable

Cable installation should start at the transition block assembly. Specific instructions are packaged with the cable for all tasks in this phase of the installation.

1. Connect cable to fitting transition block assembly.
2. Center cable over floor preparation and tape to the floor at the transition point.
3. Proceed with laying cable over floor preparation main run and edge-tape cable to the bottom shield every 1.8 to 3.7 m [6 to 12 ft.] to avoid shifting.
4. To change the direction of the cable run, fold the cable at right or left angles over itself and press firmly to crease. No cutting is required. Corners should be centered on the floor preparation and taped.
5. If the cable length is insufficient to complete the layout, splice the connectors to another cable to obtain the specified cable length.
  - a. Maintain conductor size, configuration, and polarity.
  - b. Trim cable ends square.
  - c. Allow a maximum of 3.18 mm [.125 in.] between cable ends to be spliced.
  - d. Terminate the splice connector with a Tyco Electronics Hand Tool. Install an insulator kit over the splice connectors.
  - e. Edge-tape the cable in position after installing insulator kit.
6. Lay tap circuits perpendicular to the main run.
  - a. Trim tap cable end square.
  - b. Allow a maximum of 3.18 mm [.125 in.] separation.
  - c. Terminate the tap connector with a Tyco Electronics Hand Tool. Install an insulator kit over the tap connectors.
  - d. Tape tap circuit cable in position, centered over the bottom shield.
  - e. To change the direction of the tap circuit cable, fold cable at a right angle over itself and press firmly to crease. Corners should be centered on the bottom shield and taped.
  - f. Where the tap circuit cable dead-ends at a floor fitting, trim the cable so that the squared end does not extend past the anchor screws by more than 12.7 mm [.500 in.].
7. Apply connector patches.
  - a. Care shall be taken when applying the patches to ensure that a proper environmentally sound seal is made.
  - b. Patches are to be installed over splices, taps, and unterminated cable ends.

#### G. Installing Floor Fittings

In applications where floor fittings must be installed after cables are laid, edge tape both cable edges to the floor for a length of 0.6 m [2 ft.]. With the floor fitting centered across and between the taped edges, install the floor fitting as instructed in Paragraph 3.2.D. Sweep and vacuum to remove all debris prior to the tape removal and floor fitting installation.

Tape should partially overlap the flat conductor cable, bottom shield, and the floor.

**NOTE**

*Protective tape prevents debris from getting under the cable and bottom shield while drilling the anchor holes.*

## H. Installing Top Shield

1. Begin laying the top shield main run at the transition fitting.
  - a. Proceed to lay the top shield over the main runs, cross-taping it every 1.8 to 3.7 m [6 to 12 ft.].
  - b. When laying the shield over the tap circuits, or when it is necessary to extend the length of the shield, overlap the shield 152 to 203 mm [6 to 8 in.] and place a piece of electrical tape on the flat conductor cable at the point where the lower piece of shield edge contacts the cable.
2. Splice and tap the shield, using the top shield bonding clips.
3. Terminate the top shield to the fittings and transition block assemblies.
4. After installation of top shield, conduct an electrical check to ensure there are no shorts between the hot, neutral, and ground.
5. Edge tape top shield to floor, along the complete installed cable run.

## I. Direct Connecting Receptacle (DCR) Installation

1. DCR electrical fitting installation should begin after all debris has been removed from installation of the DCR mounting base plate and after the top shield has been installed.

**NOTE**

Instructions for installing DCR fittings are packaged with the DCR assembly.



2. Perform an electrical continuity check of the hot, neutral, and ground circuits.
3. Install DCR cover fitting.

## J. Connecting Source Power

1. Instructions for connecting source power are packaged with the transition fitting block assembly covers.
2. Recommended minimum size of interconnecting wire is 12 AWG copper for 12 AWG flat cable and 10 AWG copper for 10 AWG flat cable.
3. Match color-coded round conductors to color-coded flat conductors.
4. A ground wire shall be connected from the ground binding screw on the transition block assembly to the ground terminal on or in the wall and floor electrical boxes or any other transition fitting.
5. After the source power is connected, place a piece of electrical tape over the top shield edge and install the transition fitting cover.
6. Apply power to the system and check the output of each receptacle for voltage and polarity.

## K. Installing Carpet Squares

1. Coordinate work with electrical trades to ensure that electrical power is removed from flat conductor cable circuits while carpet is being installed.
2. When cutting carpet to fit, it is important that a barrier be placed between the carpet and the cable to avoid accidentally cutting the cable.
3. Place carpet squares directly over installed top shield.
4. Cut and fit carpet to fit over or around installed fittings.

### 3.3. Materials

*Cable:* Factory laminated, abrasion resistant, color-coded, flat conductor cable.

*Top Shield:* Corrosion-resistant, cold rolled steel strip.

*Floor Preparation:* Yellow-colored, plasticized pvc sheet.

*Transition Fittings:* Zinc-plated carbon steel, AISI type 1010.

*Transition Block Assemblies:* R-10 RYTON molded blocks with associated insulators and hardware.

*Tap and Splice Cable Connectors and Top Shield Bonding Clips:* Copper alloy.

*Floor Fitting Covers:* Plastic molding compound.

*Transition Fitting Covers:* Aluminum alloy, type 5052.

### 3.4. Accessories

Spray adhesive and hold-down tape are used to attach the top shield to the floor surface.

## 4. QUALIFICATION

### 4.1. Underwriters Laboratories Inc. (UL)

Undercarpet Power cable is Listed in UL File Number E73212 and the fittings are Listed in UL File Number E73213 (per CSA International test methods).

### 4.2. CSA International

Undercarpet Power System is Certified to CSA International File Number C22.2 No. 222.

## 5. TOOLING

Undercarpet Hand Tool 91384-1 is designed to terminate tap and splice connectors onto undercarpet power cables. Refer to Instruction Sheet 408-8860 for terminating procedures. See Figure 2.

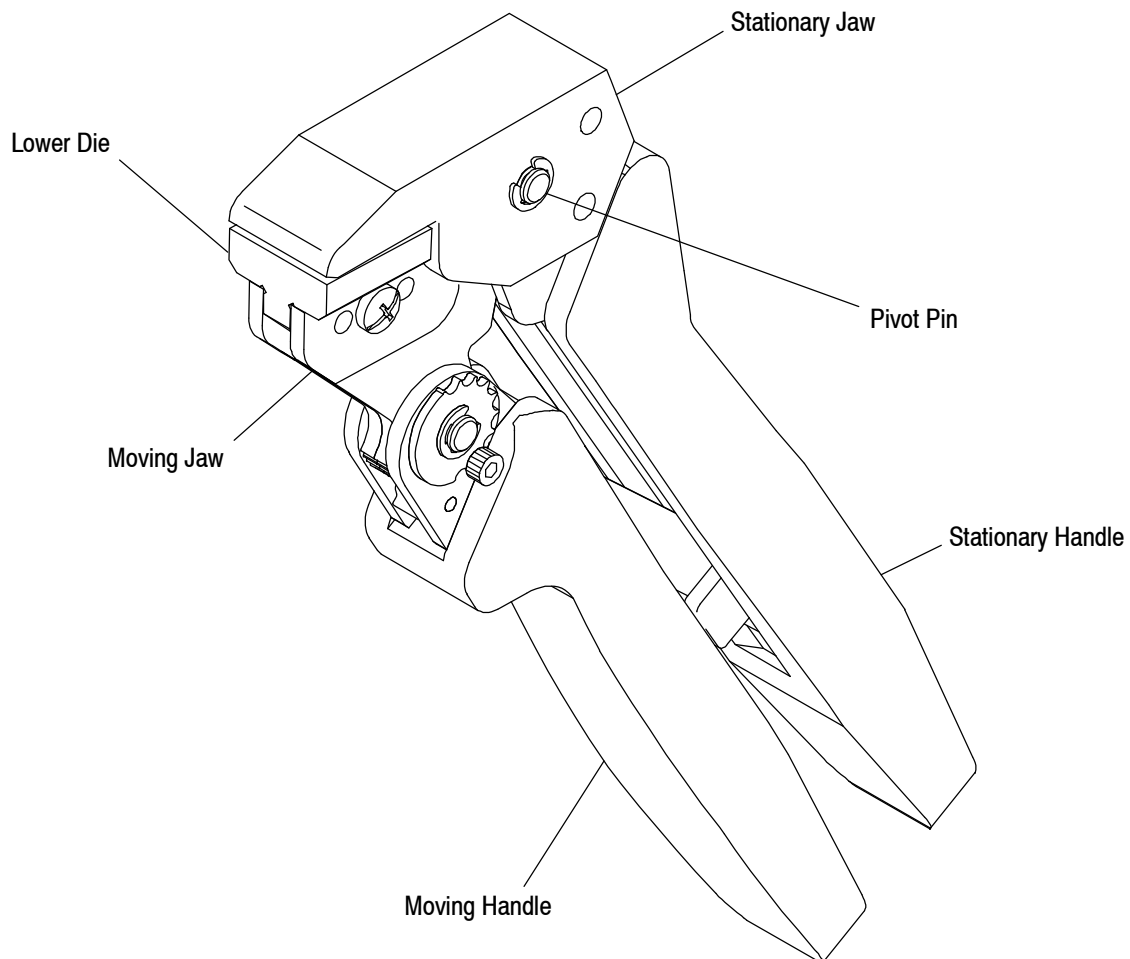

Figure 2

---

## 6. VISUAL AID

Figure 3 shows a typical application of an Undercarpet Power System. This illustration should be used by installation personnel to ensure a correctly applied product. Applications which DO NOT appear correct should be inspected using the information in the preceding pages of this specification and in the instructional material shipped with the product.

---

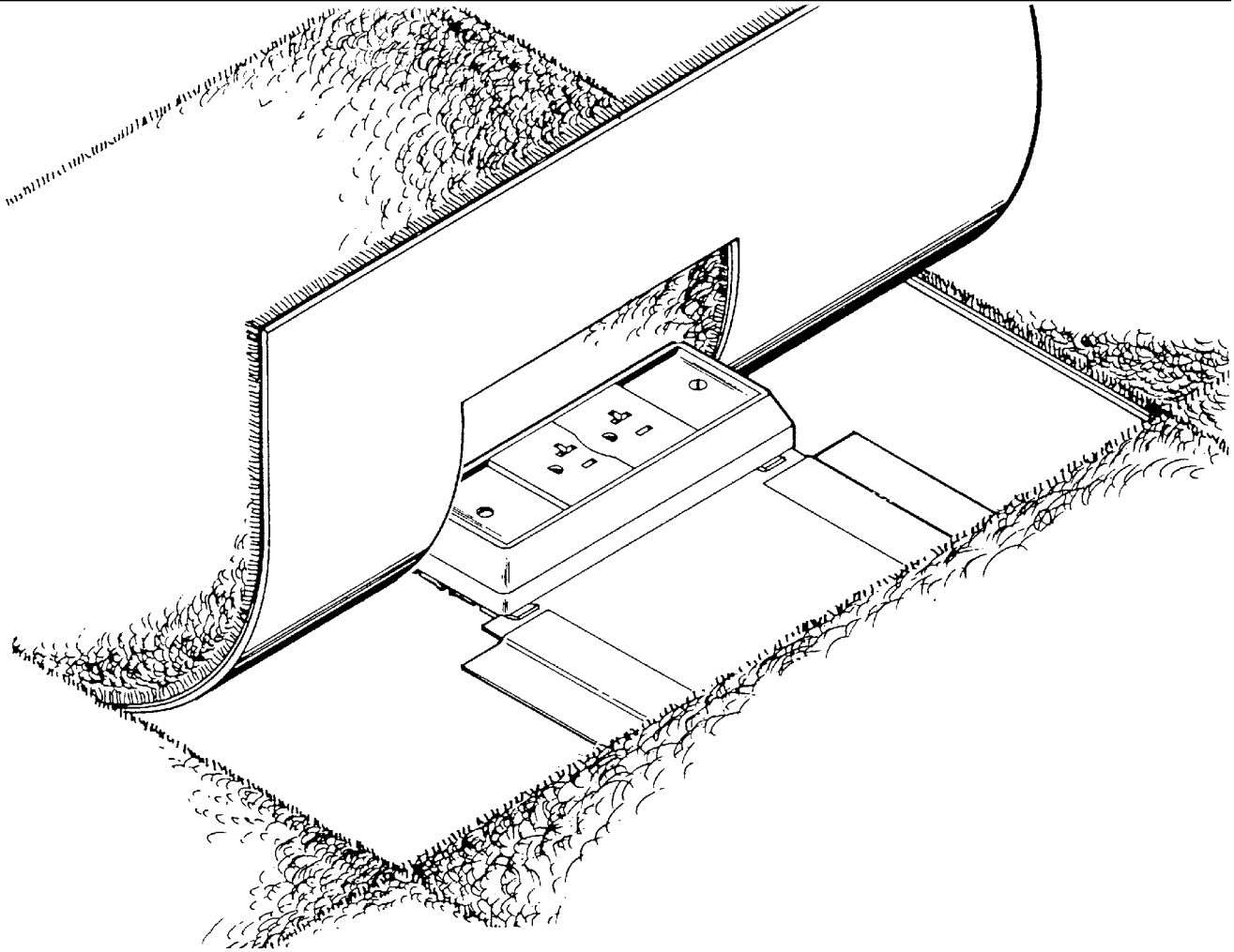

---

**FIGURE 3. VISUAL AID**