

Flextray™ - Wall Support Methods



Wall Supports



Shelf Brackets

- Heavy-duty support bracket
- For use with 6" (150mm) to 24" (600mm) wide trays
- Built-in tab for hold down
- Optional hardware sold separately
- Finishes __: **GLV**, HDG, SS6

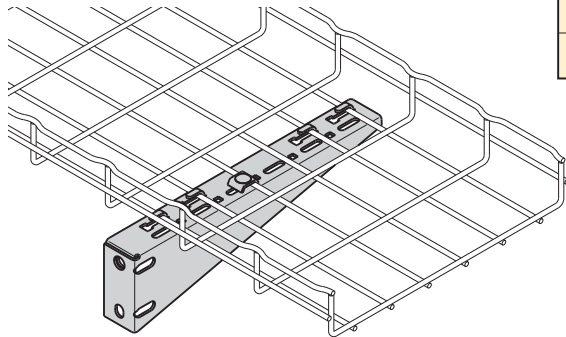

Part Number	Use With Tray Width	Qty./Box	Wt./Box	
			lbs.	kg
FTB06CS __	6" (150mm)	1	0.5	0.22
FTB08CS __	8" (200mm)	1	0.6	0.27
FTB12CS __	12" (300mm)	1	1.2	0.54
FTB16CS __	16" (400mm)	1	1.7	0.77
FTB18CS __	18" (450mm)	1	1.9	0.86
FTB20CS __	20" (500mm)	1	2.6	1.18
FTB24CS __	24" (600mm)	1	3.2	1.45

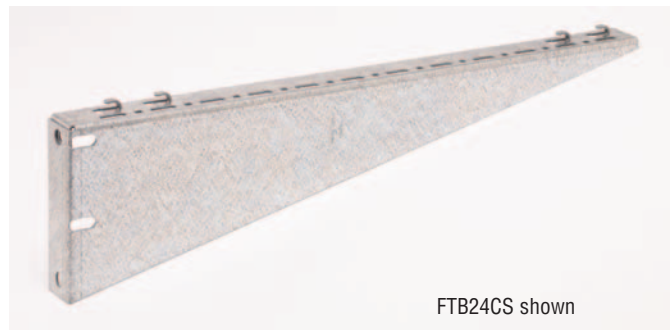

FTB24CS shown

L Brackets

- Installs tray to wall cleanly
- Built-in tab for hold down (not available in stainless steel)
- For use with 4" (100mm) to 24" (600mm) wide trays
- Use with pedestal clamp in raised floor applications
- Hardware sold separately
- Finishes __: **EG**, HD, BLE, 316S

Part Number	Use With Tray Width	Qty./Box	Wt./Box	
			lbs.	kg
4 L BRKT __	4" (150mm)	1	0.6	0.27
8 L BRKT __	6" (150mm) & 8" (200mm)	1	0.8	0.36
12 L BRKT __	12" (300mm)	1	1.3	0.59
16 L BRKT __	16" (400mm)	1	1.4	0.63
20 L BRKT __	18" & 24" (450 & 500mm)	1	2.0	0.91
24 L BRKT __	24" (600mm)	1	2.3	1.04

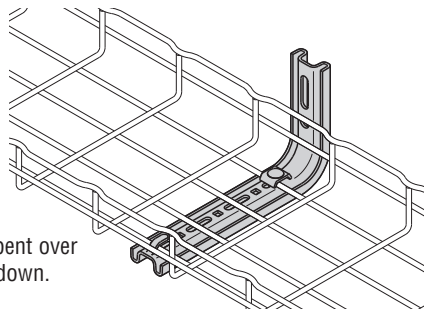

Tab can be bent over for hold down.

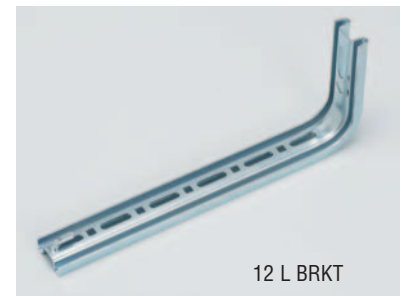

12 L BRKT

See page - 2 for finish information

Flextray™ - Wall Support Methods

Z Brackets

Part Number	Description	Qty./Box	Wt./Box	
			lbs.	kg
Z BRKT__	Z Bracket	1	0.6	0.27

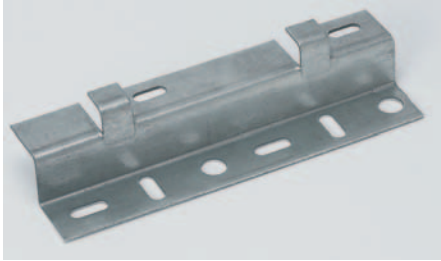

- Used for horizontal and/or vertical mounting
- 8" (200mm) wide bracket for use with 4" (100mm) to 32" (800mm) wide trays
- Can be used to offset trays from floor
- Can be used to terminate tray run at wall
- Multiple brackets can be used for wider tray widths
- Finishes __: **GS**, BLE

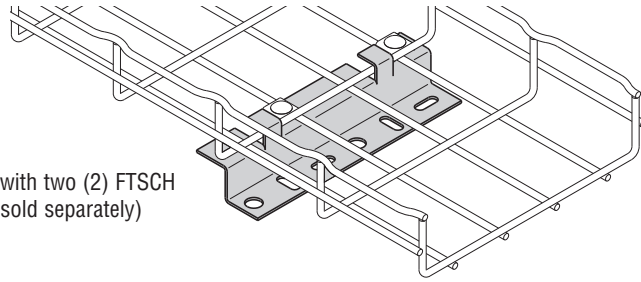

Use with two (2) FTSCH
(sold separately)

Hold Down Plate

Part Number	Slot Size	Qty./Box	Wt./Box	
			lbs.	kg
SUPT WASHER__	.28" x .70"	50	4.7	2.13
FTA6HD__	.40" x .70"	50	3.5	1.59

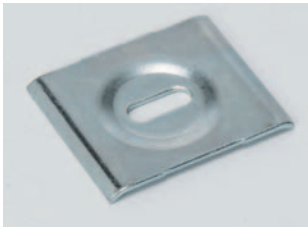

- Easy way to mount 4" (100mm) wide tray for raceway run.
- Use 1/4" screws to attach SUPT WASHER to your specific wall/stud application (hardware sold separately).
- FTA6HD can be used in pairs to create a center-hung support using 3/8" rod.
- To protect cables use threaded rod protector (page 61).
- To complete 3/8" center hanger assembly use:
 - 2 - FTA6HD
 - 2 - HN 3/8"-16 hex nuts
- Finish: **ZN**, SS6

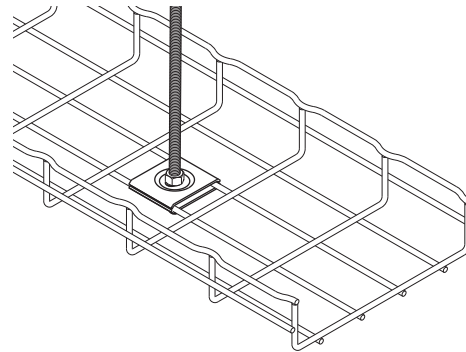
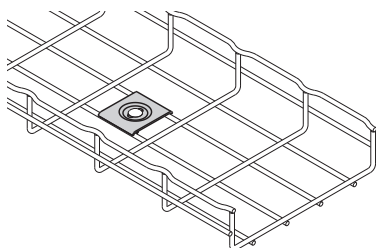

See page 44 for finish information

Attachment Clips

- Wall attachment for 2" (50mm) wide tray only (FT2X2X10)
- Low-profile appearance
- Built-in tab to hold down tray
- Can also be used with 2" (50mm) Center Hanger (see page 60)
- Hardware sold separately
- Finishes __: **GS**, BLE

Part Number	Description	Qty./Box	Wt./Box	
			lbs.	kg
ATTACHMENT CLP__	Attachment Clip Support for FT2x2x10	50	3.4	1.54

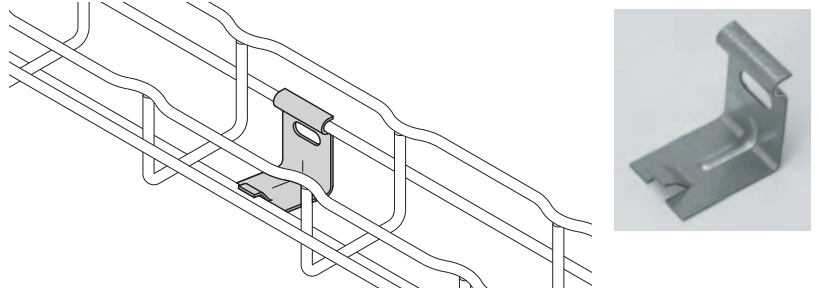

Mounting Bracket

- Designed to support FT2X2X10 Flextray
- Click tabs for Flextray attachment
- Use 1/4" hardware and washer (not included) to mount bracket
- Finishes __: **SS6**

Part Number	Description	Qty./Box	Wt./Box	
			lbs.	kg
FTB2UB__	Light Duty Wall/Rack Bracket	10	2.1	0.95

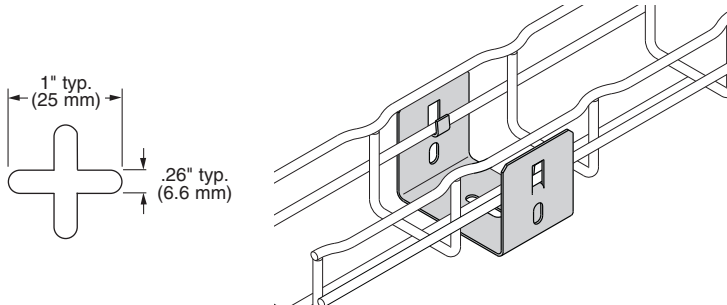

Wall Supports

- Use to attach 2" (50mm) or 4" (100mm) trays to walls, struts or cabinets
- Use for raceway mounting
- Mount to metal framing for vertical support
- Tabs are built in for tray hold down
- Mount to side rail for electrical box connection
- Finishes __: **GLV**

Part Number	Description	Qty./Box	Wt./Box	
			lbs.	kg
FTA050CC__	Wall Support Bracket	1	0.8	0.36

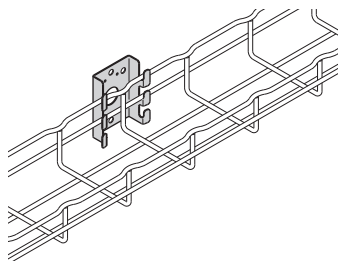

See page - 2 for finish information

Flextray™ - Wall Support Methods

Wall Termination Kit

Part Number	Length	Qty./Box	Wt./Box	
			lbs.	kg
FTA9WTK__	9"	1	1.3	0.59

- Kit includes all hardware necessary to support Flextray when terminated at a wall
- Mount slotted angle to wall with up to 3/8" hardware (not included)
- Finishes __: **ZN**, FB, SS6

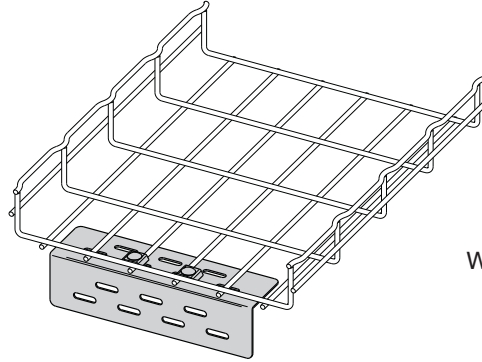
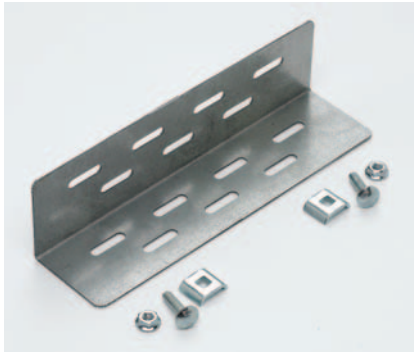

Wall Termination Kit includes:
 1 - Angle with Slots
 2 - FTSCH

Wall Mount Kit

Part Number	Length	Qty./Box	Wt./Box	
			lbs.	kg
WB48WMK__	8"	1	0.76	0.35
WB1224WMK__	12"	1	1.22	0.55

- Kit includes all components necessary to mount Flextray to a wall horizontally or vertically
- Mount strut to wall with up to 1/2" hardware (not included)
- Finish: Channel - **GLV**
 Hardware - **ZN**
 Available in SS6

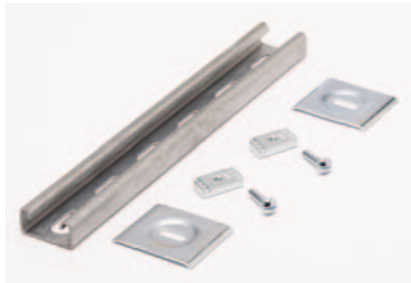

WB1224WMK shown

Wall Mount Kit includes:

WB48WMK	WB1224WMK	
1	1	B54SH Strut
1	2	SUPT WASHER Hold Downs
1	2	1/4"-20 x 1" Slotted Head Screw
1	2	N224WO Channel Nut

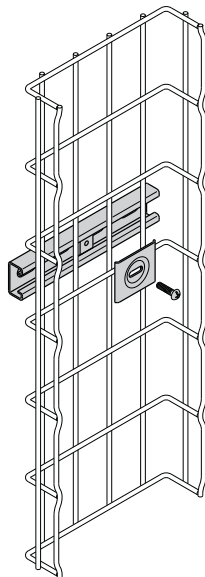

Vertically Mounted

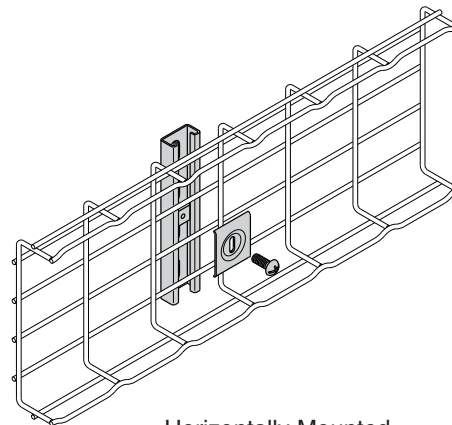

Horizontally Mounted

See page - 2 for finish information

C Brackets

- Tab can be used for hold down (stainless steel will not have these tabs)
- For use with 4" (100mm) to 12" (300mm) wide trays
- C Bracket attaches to hard ceiling types
- All brackets are 7⁷/₈" (200mm) tall
- Cables can be side loaded
- L Brackets (page 27) and C Brackets can be combined for layered tray runs
- Finishes __: **EG**, BLE, HD

Part Number	Description	Qty./Box	Wt./Box	
			lbs.	kg
4 C BRKT__	4" (100mm) C Bracket	1	1.2	0.54
8 C BRKT__	8" (200mm) C Bracket	1	1.4	0.63
12 C BRKT__	12" (300mm) C Bracket	1	1.9	0.86

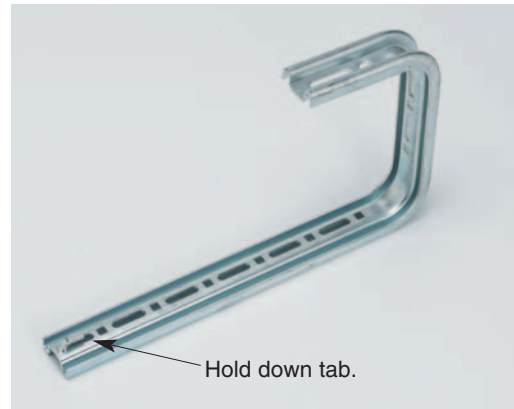
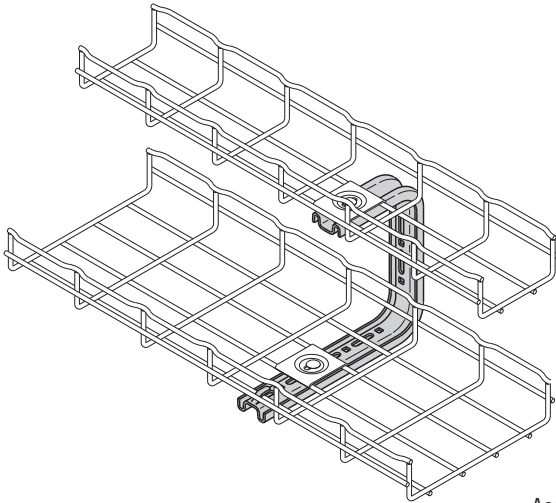

Assemble with
SUPT WASHER &
FTHDWE 1/4.

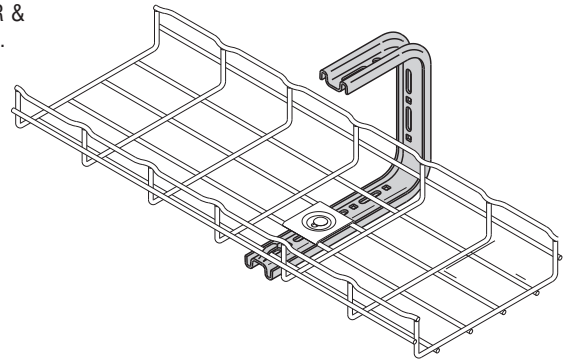
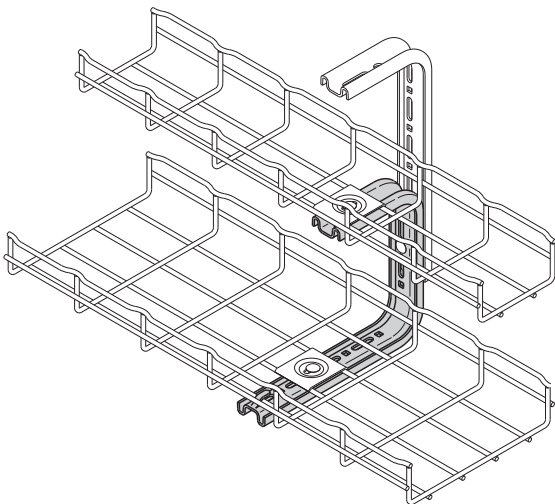

See page - 2 for finish information